

ASCARI™ CREDENZA

Planning Guide + Price List

QUICK LINKS

[PLANNING GUIDE](#)

[ASCARI CREDENZA PRICING](#)

[GENERAL INFORMATION](#)

[FINISH INFORMATION](#)

[SURFACE MATERIALS](#)



TABLE OF CONTENTS

Click the shortcuts below to jump to each section.

General Information	ii-iii
Finish Information	iv-v
Surface Materials	vi-ix
Specification Overview	3
Statement of Line	4
Material Options	5
Step 1: Case Style	6
Case Dimensions	7
Step 2: Top Material and Edge Profile	8-9
Step 3: Door & Drawer Style	10
Step 4: Pull Style	11
Pull Finish Selections	12
Step 5: Hardware Options	13
Hardware Finish Selections	14
Step 6: Case Configuration	15-18
Low Height with Plinth Base	15
Conference Height with Metal Base	15
Conference Height with Plinth Base	16
Buffet Height with Metal Base	16
Components	17
Component Dimensions	18
Step 7: Accessories	19
PRICE LIST	
Low Height Credenza with Plinth Base	20-23
72 x 18 x 25 Standard Case 72/75.5 x 18 x 25 Beveled Case	20
72 x 24.5 x 25 Standard Case 72/76.75 x 24.5 x 25 Beveled Case	21
108 x 18 x 25 Standard Case 108/111.5 x 18 x 25 Beveled Case	22
108 x 24.5 x 25 Standard Case 108/112.75 x 24.5 x 25 Beveled Case	23
Conference Height Credenza with Metal Base	24-27
72 x 18 x 30 Standard Case 72/75.5 x 18 x 30 Beveled Case	24
72 x 24.5 x 30 Standard Case 72/76.75 x 24.5 x 30 Beveled Case	25
108 x 18 x 30 Standard Case 108/111.5 x 18 x 30 Beveled Case	26
108 x 24.5 x 30 Standard Case 108/112.75 x 24.5 x 30 Beveled Case	27
Conference Height Credenza with Plinth Base	28-31
72 x 18 x 30 Standard Case 72/75.5 x 18 x 30 Beveled Case	28
72 x 24.5 x 30 Standard Case 72/76.75 x 24.5 x 30 Beveled Case	29
108 x 18 x 30 Standard Case 108/111.5 x 18 x 30 Beveled Case	30
108 x 24.5 x 30 Standard Case 108/112.75 x 24.5 x 30 Beveled Case	31
Buffet Height Credenza with Metal Base	32-35
72 x 18 x 34 Standard Case 72/75.5 x 18 x 34 Beveled Case	32
72 x 24.5 x 34 Standard Case 72/76.75 x 24.5 x 34 Beveled Case	33
108 x 18 x 34 Standard Case 108/111.5 x 18 x 34 Beveled Case	34
108 x 24.5 x 34 Standard Case 108/112.75 x 24.5 x 34 Beveled Case	35
Additional Accessories	36

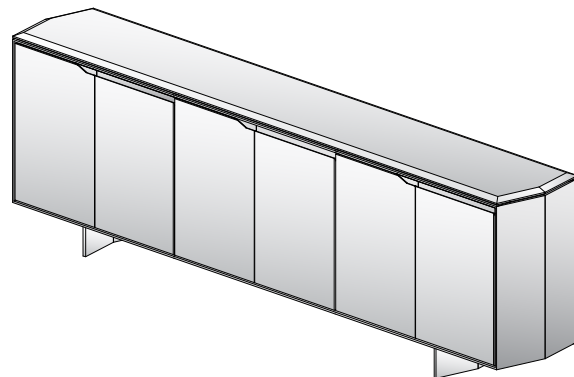



STATEMENT OF LINE

To start specification, click on your preferred measurements below to be directed to the appropriate price list page. Special sizes require a quote.

LOW HEIGHT WITH PLINTH BASE

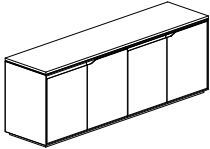

Standard Case
[72" L x 18" D x 25" H](#)
[72" L x 24.5" D x 25" H](#)

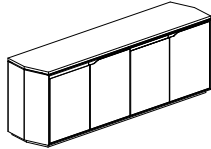

Beveled Case
[72"/75.5" L X 18" D X 25" H](#)
[72"/76.75" L X 24.5" D X 25" H](#)

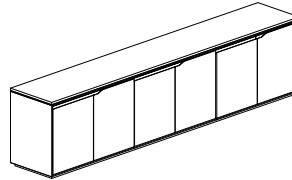

Standard Case
[108" L x 18" D x 25" H](#)
[108" L x 24.5" D x 25" H](#)

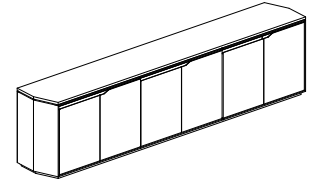

Beveled Case
[108"/111.5" L X 18" D X 25" H](#)
[108"/112.75" L X 24.5" D X 25" H](#)

CONFERENCE HEIGHT WITH METAL BASE

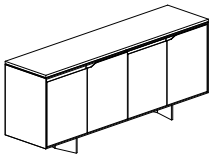

Standard Case
[72" L x 18" D x 30" H](#)
[72" L x 24.5" D x 30" H](#)

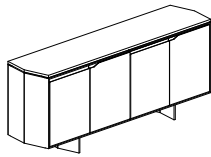

Beveled Case
[72"/75.5" L X 18" D X 30" H](#)
[72"/76.75" L X 24.5" D X 30" H](#)

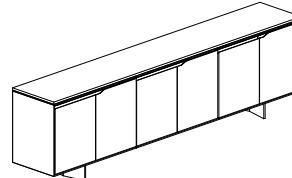

Standard Case
[108" L x 18" D x 30" H](#)
[108" L x 24.5" D x 30" H](#)

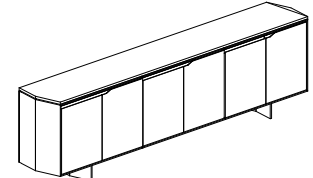

Beveled Case
[108"/111.5" L X 18" D X 30" H](#)
[108"/112.75" L X 24.5" D X 30" H](#)

CONFERENCE HEIGHT WITH PLINTH BASE

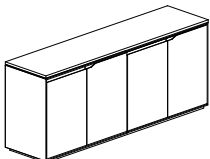

Standard Case
[72" L x 18" D x 30" H](#)
[72" L x 24.5" D x 30" H](#)

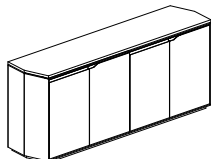

Beveled Case
[72"/75.5" L X 18" D X 30" H](#)
[72"/76.75" L X 24.5" D X 30" H](#)

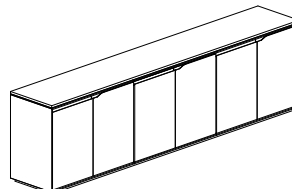

Standard Case
[108" L x 18" D x 30" H](#)
[108" L x 24.5" D x 30" H](#)

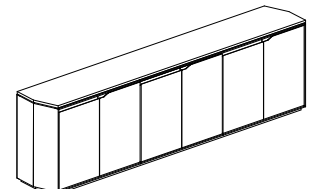

Beveled Case
[108"/111.5" L X 18" D X 30" H](#)
[108"/112.75" L X 24.5" D X 30" H](#)

BUFFET HEIGHT WITH METAL BASE

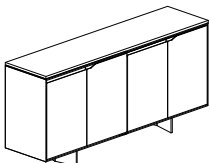

Standard Case
[72" L x 18" D x 34" H](#)
[72" L x 24.5" D x 34" H](#)

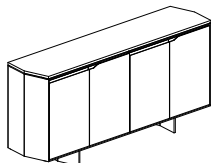

Beveled Case
[72"/75.5" L X 18" D X 34" H](#)
[72"/76.75" L X 24.5" D X 34" H](#)

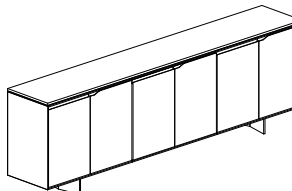

Standard Case
[108" L x 18" D x 34" H](#)
[108" L x 24.5" D x 34" H](#)

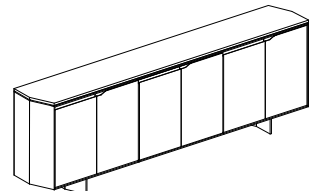

Beveled Case
[108"/111.5" L X 18" D X 34" H](#)
[108"/112.75" L X 24.5" D X 34" H](#)



SPECIFICATION OVERVIEW

STEP 1: CASE STYLE

Choose a standard or beveled case, available in painted or wood veneer finish.

STEP 2: TOP MATERIAL AND EDGE PROFILE

Veneer and stone available with square or chamfer edge profile. Laminate, Fenix®, and glass available with a square edge profile.

STEP 3: DOOR/DRAWER STYLE

Doors and drawers will match case finish, unless specified.

Choose from three veneer patterns or painted door/drawer fronts.

STEP 4: PULL STYLE

Metal pull styles include Integrated, Tab, or Handle pull for ADA accommodation.

STEP 5: HARDWARE OPTIONS

Choose optional locks, raised backstop, or a metal edge reveal, if desired. Metal Base available in powder coat or polished chrome.

STEP 6: CASE CONFIGURATION

Select configuration and desired components for each cabinet location.

With seven different door, drawer, and shelf configurations available, choose the combination that fits your needs. Components include pull out waste/recycling, drawer refrigerator, charging drawers or equipment racks and trays.

STEP 7: ACCESSORIES

Drawer inserts include fabric drawer liners and organizers to fit any closed box drawer. Peg board systems for deep drawer organization fit any large box drawer.

SPECIFICATION EXAMPLE: ACLC-7225-VC-V-VD-MIP-MR-DD-A-DD-B-ACPOS-24

ACLC-7225	-VC	-V	-VD	-MIP	-RB	-DD-A-DD-B-ACPOS-24
MODEL NUMBER	CASE STYLE	TOP MATERIAL AND EDGE PROFILE	DOOR/DRAWER STYLE	PULL STYLE	HARDWARE OPTIONS (IF APPLICABLE)	CASE CONFIGURATION



MATERIAL OPTIONS

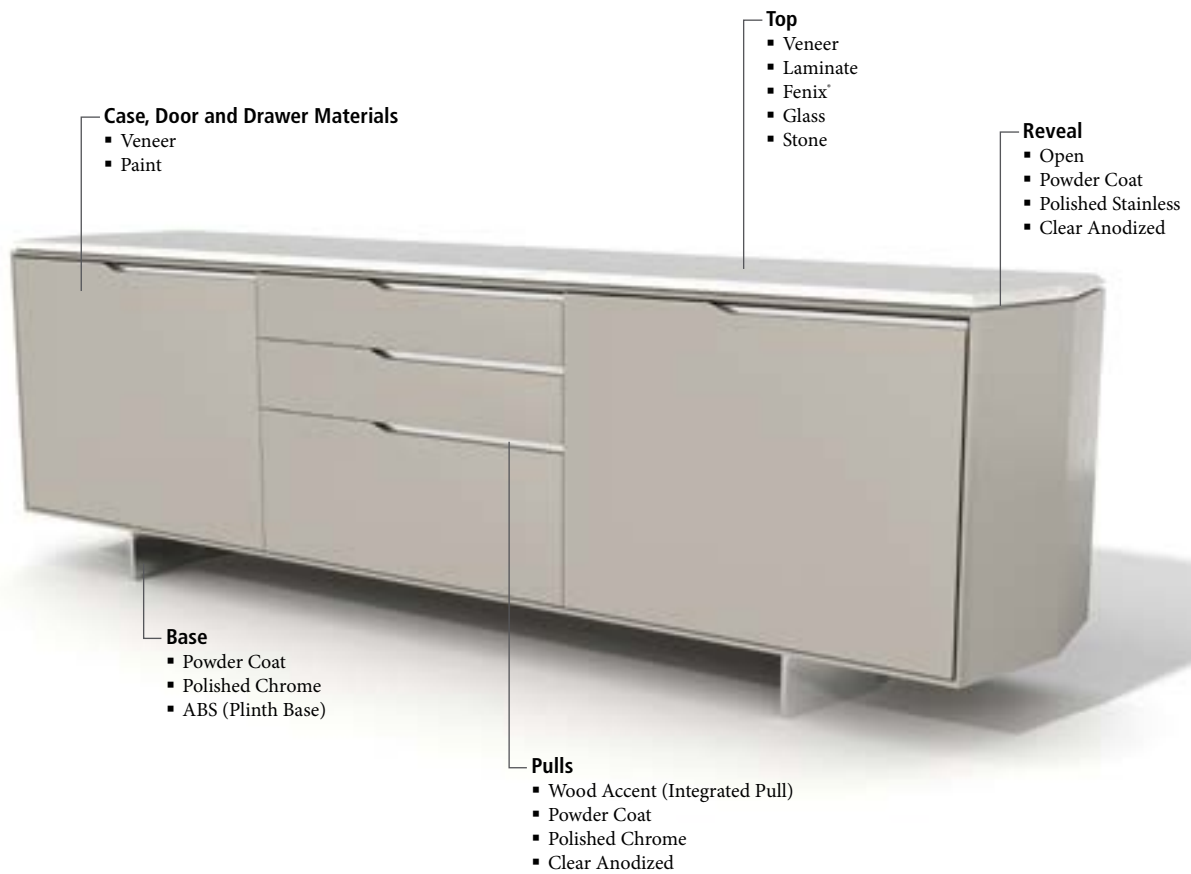



STEP 1: CASE STYLE

Choose a standard or beveled case, available painted or veneer.

STANDARD CASE

- Premium aesthetic with mitered case construction and flush, finished back
- Two or three case assembly for ease of handling
- Available in veneer or paint
 - Painted or veneer case interior finish will match exterior finish
 - Veneer direction will run vertical with a slip-match layup
- Plinth or metal base
 - 1.5" plinth base inset with black finish
 - 5.75" beveled metal base. Finish must be specified.

Low Height with Plinth Base

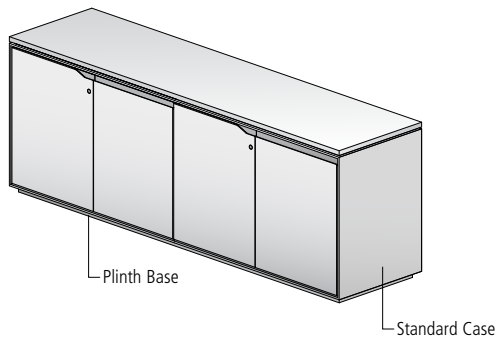

Conference Height with Metal Base

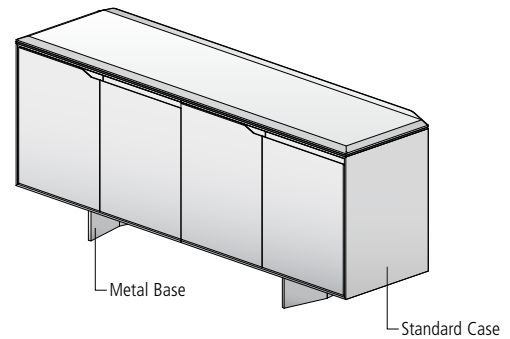

BEVELED CASE

- Offers striking bevels on each end and correlating bevel shaped top
- Premium aesthetic with mitered case construction and flush, finished back.
- Two or three case assembly for ease of handling
- Available in veneer or paint
 - Painted or veneer case interior finish will match exterior finish
 - Veneer direction will run vertical with a slip-match layup
- Plinth or metal base
 - 1.5" plinth base inset with black finish
 - 5.75" beveled metal base. Finish must be specified.

Conference Height with Plinth Base

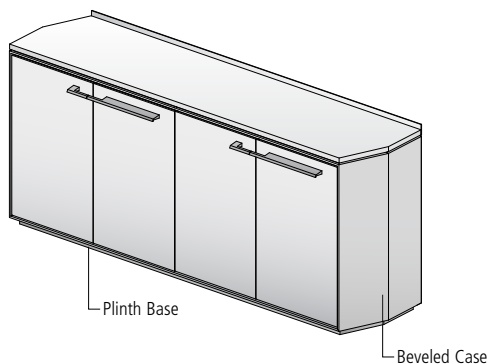

Buffet Height with Metal Base

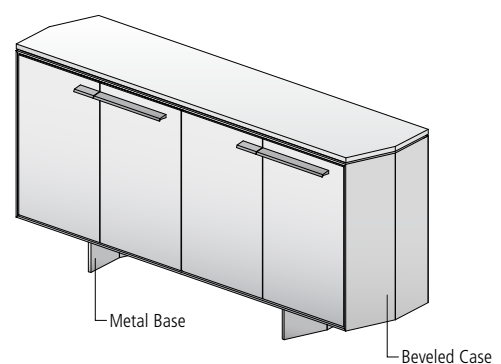



CASE DIMENSIONS

DIMENSIONS

All Credenzas include vertical panels that divide the interior into two or three sections depending on credenza width. Dimensions A, B, and C reflect the width of each section. Exterior heights excludes top material thickness. Add top material for total height:

Veneer, Laminate, Fenix® and Stone - .75"

Veneer | Thick Edge - 2"

Glass - .375"

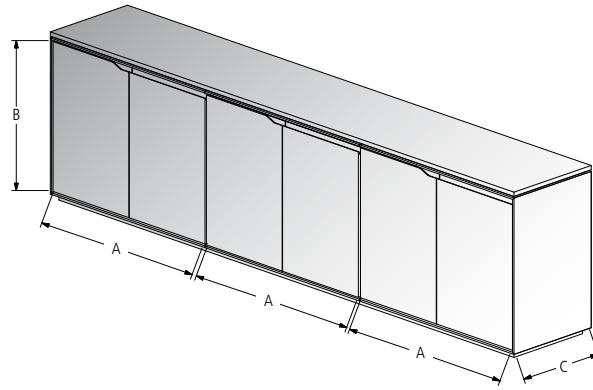

STANDARD CASE

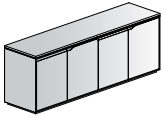

LOW HEIGHT WITH PLINTH BASE

Exterior Dimensions	Interior Dimensions		
	A	B	C
72"W x 18"D x 25.25"H	34.4	22	16
108"W x 18"D x 25.25"H	34.4	22	16
72"W x 24.5"D x 25.25"H	34.4	22	22.5
108"W x 24.5"D x 25.25"H	34.4	22	22.5

BEVELED CASE

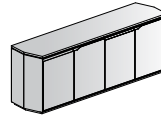

LOW HEIGHT WITH PLINTH BASE

Exterior Dimensions	Interior Dimensions		
	A	B	C
75.5"W x 18"D x 25.25"H	34.4	22	16
111.5"W x 18"D x 25.25"H	34.4	22	16
76.75"W x 24.5"D x 25.25"H	34.4	22	22.5
112.75"W x 24.5"D x 25.25"H	34.4	22	22.5

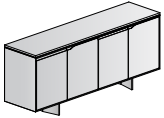

CONFERENCE HEIGHT WITH METAL BASE

Exterior Dimensions	Interior Dimensions		
	A	B	C
72"W x 18"D x 29.5"H	34.4	22	16
108"W x 18"D x 29.5"H	34.4	22	16
72"W x 24.5"D x 29.5"H	34.4	22	22.5
108"W x 24.5"D x 29.5"H	34.4	22	22.5

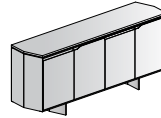

CONFERENCE HEIGHT WITH METAL BASE

Exterior Dimensions	Interior Dimensions		
	A	B	C
75.5"W x 18"D x 29.5"H	34.4	22	16
111.5"W x 18"D x 29.5"H	34.4	22	16
76.75"W x 24.5"D x 29.5"H	34.4	22	22.5
112.75"W x 24.5"D x 29.5"H	34.4	22	22.5

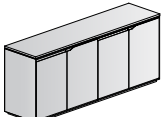

CONFERENCE HEIGHT WITH PLINTH BASE

Exterior Dimensions	Interior Dimensions		
	A	B	C
72"W x 18"D x 29.25"H	34.4	26	16
108"W x 18"D x 29.25"H	34.4	26	16
72"W x 24.5"D x 29.25"H	34.4	26	22.5
108"W x 24.5"D x 29.25"H	34.4	26	22.5

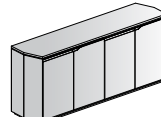

CONFERENCE HEIGHT WITH PLINTH BASE

Exterior Dimensions	Interior Dimensions		
	A	B	C
75.5"W x 18"D x 29.25"H	34.4	26	16
111.5"W x 18"D x 29.25"H	34.4	26	16
76.75"W x 24.5"D x 29.25"H	34.4	26	22.5
112.75"W x 24.5"D x 29.25"H	34.4	26	22.5

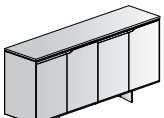

BUFFET HEIGHT WITH METAL BASE

Exterior Dimensions	Interior Dimensions		
	A	B	C
72"W x 18"D x 33.5"H	34.4	26	16
108"W x 18"D x 33.5"H	34.4	26	16
72"W x 24.5"D x 33.5"H	34.4	26	22.5
108"W x 24.5"D x 33.5"H	34.4	26	22.5

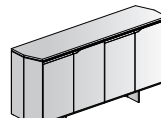

BUFFET HEIGHT WITH METAL BASE

Exterior Dimensions	Interior Dimensions		
	A	B	C
75.5"W x 18"D x 33.5"H	34.4	26	16
111.5"W x 18"D x 33.5"H	34.4	26	16
76.75"W x 24.5"D x 33.5"H	34.4	26	22.5
112.75"W x 24.5"D x 33.5"H	34.4	26	22.5

STEP 2: TOP MATERIAL AND EDGE PROFILE

Choose between laminate, veneer, Fenix®, glass, or stone top materials. Square or chamfer edge profiles available. (chamfer option limited to veneer and stone tops)

- 72" and 108" -length one piece tops
- Standard case receives rectangle-shape top
- Beveled case receives correlating bevel-shape top
- Applied edge finish will coordinate with top material finish
- Slight height variations dependent upon the surface material selected

TOP WITH SQUARE EDGE

▪ Veneer with Hardwood Edge

- Veneer tops available with either a Square or 2" Thick edge
- Square edge features a 3/4"-thick veneer top with 3/16"-depth hardwood square edge band
- 2" Thick edge features a 2"-thick veneer top with a 3/16"-depth hardwood square edge band
- Coordinates with Ascari Casegood
- If no direction is provided, default sheen will be selected
- Veneer direction will run the length of the credenza

▪ Laminate with ABS Edge

- 3/4"-thick laminate top with 2mm square edge
- Solid and patterned laminates receive a solid color ABS square edge band
- Woodgrain laminates receive a matching woodgrain PVC square edge band

▪ Laminate with Hardwood Edge

- 3/4"-thick laminate top with 3/16"-depth hardwood square edge band
- Edge finish will match veneer case finish
- If painted case is specified, wood finish must be selected

▪ Fenix® with ABS Edge

- 3/4"-thick Fenix® top with 1mm square edge
- Edge application will default to matching ABS edge band

▪ Fenix® with Hardwood Edge

- 3/4"-thick Fenix® top with 3/16"-depth hardwood square edge band
- Edge finish will match veneer case finish
- If painted case is specified, wood finish must be selected

▪ Gloss Glass

- 3/8"-thick back-painted, low-iron glass top with square edge

▪ Satin Glass

- 3/8"-thick back-painted, low-iron glass top with square edge

▪ Stone

- 2cm thick stone top with square edge

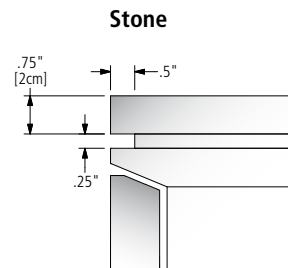
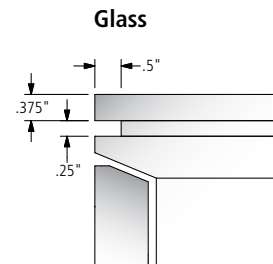
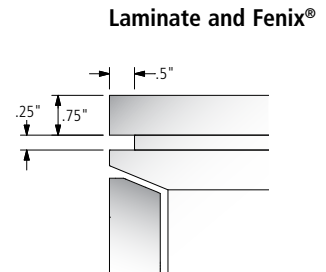
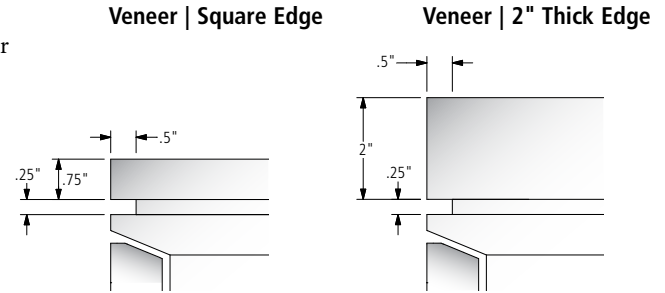



STEP 2: TOP MATERIAL AND EDGE PROFILE

TOP WITH CHAMFER EDGE

▪ Veneer

- 3/4"-thick veneer top with 1-1/4"-depth chamfer edge
- If no direction is provided, default sheen will be selected

▪ Stone

- 2cm thick stone/quartz top with 2"-depth chamfer edge

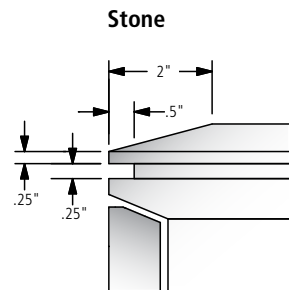
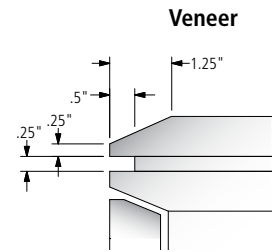



STEP 3: DOOR/DRAWER STYLE

Doors and drawers will match case finish, unless specified. You may choose from three veneer patterns or painted door/drawer fronts.

STANDARD CASE

BEVELED CASE

PAINT

- Applied to veneer or painted case
- Available in all paint finishes
- Door and drawer style will match painted case finish, unless specified
- If veneer case is specified, paint finish must be selected

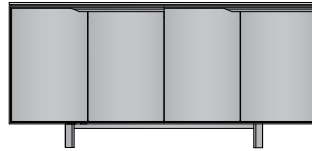

VERTICAL VENEER

- Vertical veneer direction features a slip-match layup
- Applied to painted or veneer case
- Available in all wood finishes
- Door and drawer style will match veneer case finish, unless specified
- If painted case is specified, wood finish must be selected



HORIZONTAL VENEER

- Horizontal veneer direction features a slip-match layup or book-match (available in Ash, Cherry, and Walnut)
- Applied to painted to veneer case
- Available in all wood finishes
- If veneer case is specified, case veneer direction will be vertical with slip-match layup
- If painted case is specified, wood finish must be selected

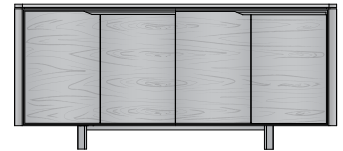
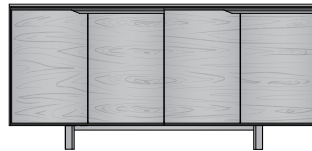

PLANK VENEER

- Plank veneer offers dramatic horizontal variations in veneer leaf color, length, and natural characteristics; simulates randomly matched veneers.
- Applied to painted or veneer Case
- Available in plank walnut
- If a veneer case is specified, case finish will default to flat-cut (non-plank) clear coat walnut. Coordinating case finish captures color variation to complement the variation of the plank door style. Case veneer direction will be vertical with slip-match layup.
- If a veneer top is specified, top finish will default to flat-cut (non-plank) clear coat walnut

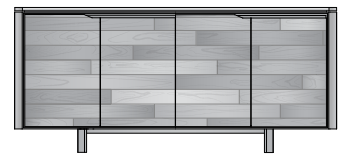
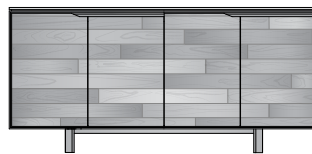



STEP 4: PULL STYLE

Pull styles include Integrated, Metal Tab, or Handle pull for ADA accommodation.

INTEGRATED PULL

Available in three finishes: metal powder coat, clear anodized, or polished chrome

- **Metal finish must be specified**
- Optional wood accent can be applied to Integrated pull front to match a veneer case or select a wood veneer finish to accent a painted case
- Coordinates with Ascari Casegood

Integrated Pull
Pull-out Single Door

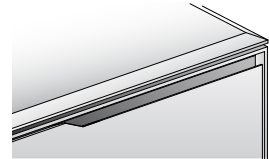

Integrated Pull
Double Door or Seamed Pull-out Single Door

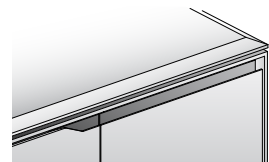

METAL TAB PULL

Universal design available in metal powder coat, clear anodized, or polished chrome

- **Metal finish must be specified**
- Coordinates with Ascari Casegood

Metal Tab Pull
Pull-out Single Door

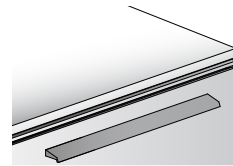

Metal Tab Pull
Double Door or Seamed Pull-out Single Door

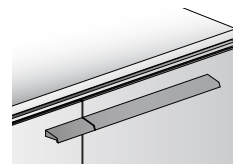

HANDLE PULL

Available in metal powder coat, clear anodized, or polished chrome

- **Metal finish must be specified**
- Handle pull is ADA compliant

Handle Pull
Pull-out Single Door

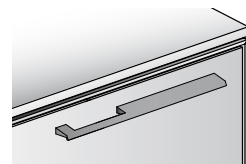

Handle Pull
Double Door or Seamed Pull-out Single Door

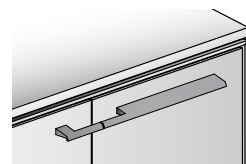

STEP 5: HARDWARE OPTIONS

Choose locks, raised backstop, or a metal edge reveal, if desired. Metal base available in powder coat or three premium metal finishes.

LOCKS

- Optional on all drawer and door cabinets
- Unavailable on pull-out single door with waste/recycling or refrigerator drawer
- Veneer finish selection will receive satin nickel locks
- Paint or powder coat finish selections will receive coordinated lock finish: white, black, or satin nickel
- Polished chrome pull selection will receive polished nickel locks

RAISED BACKSTOP

- Available in three finishes: metal powder coat, clear anodized, or polish stainless
- 1.5"-height (from surface) x .125"-thick
- Backstop will receive square corners when top with square edge is specified
- Backstop will receive chamfer corners when top with chamfer edge is specified

METAL REVEAL

- Metal inlay between case and top
- Available in three finishes: metal powder coat, clear anodized, or polish stainless
- Credenza comes standard with open reveal between case and top
- Reveal is .25"-height x .5"-depth

METAL BASE

- Available in powder coat or polished chrome
- Finish must be specified if Metal Base selected

Low Height with Plinth Base
Standard Case

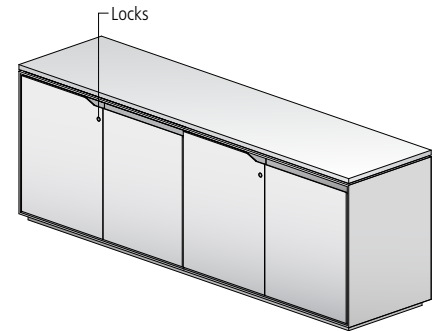

Conference Height with Plinth Base
Beveled Case

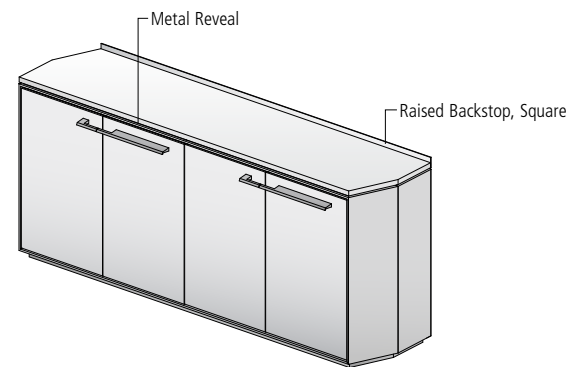

Conference Height with Metal Base
Standard Case

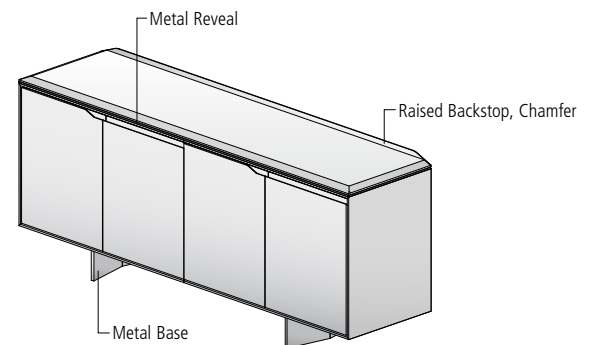

Buffet Height with Metal Base
Beveled Case

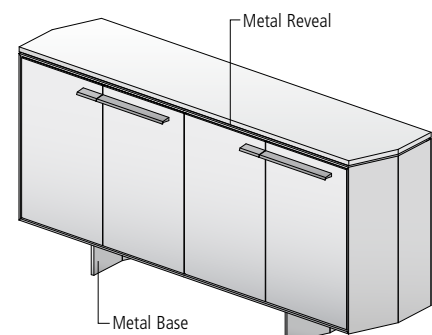



STEP 6: CASE CONFIGURATION

LOW HEIGHT WITH PLINTH BASE
CONFERENCE HEIGHT WITH METAL BASE

Select configuration and desired components for each cabinet location. **Defaults to Double Doors with Adjustable Height Shelves in all locations, if none selected.**



DOUBLE DOOR

- Includes adjustable shelf behind double doors
- Available on all credenzas



PULL OUT SINGLE DOOR

- 36" pull-out door front
- Available with pull-out waste/recycling on 24.5"-depth credenzas



SEAMED PULL-OUT SINGLE DOOR

- Center seamed vertical accent on door front to match double doors
- 36" pull-out door front
- Available with pull-out waste/recycling on 24.5"-depth credenzas

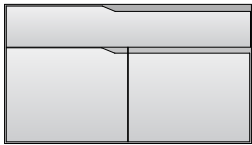

BOX DRAWER / DOUBLE DOORS

- Includes Knoll Felt, Pewter drawer liners; additional Knoll Felt or Brisa® UltraFabrics® drawer liner inserts available
- 16" -height doors
- White melamine drawer box construction and undermount soft closing glides
- Available on all credenzas

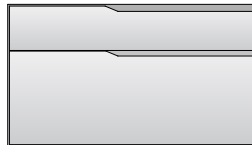

BOX DRAWER / LARGE BOX DRAWER

- Includes Knoll Felt, Pewter drawer liners; additional Knoll Felt or Brisa® UltraFabrics® drawer liner inserts available
- 36" large box drawer below
- White melamine drawer box construction and undermount soft closing glides
- Available on all credenzas

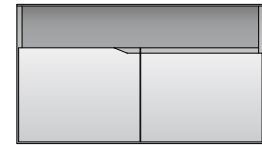

CENTER BOX / DOUBLE DOORS

- Includes adjustable shelf behind double doors
- Available on 108" credenzas
- 16" -height doors



CENTER BOX / LARGE BOX DRAWER

- 36" large box drawer below
- Available on 108" credenzas

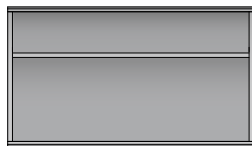

CENTER BOX / OPEN

- Open shelf storage includes a single adjustable height shelf
- Available on 108" credenzas

Box Drawer / Double Doors
D1DD

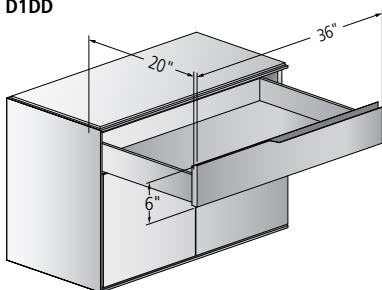

Center Box / Large Box Drawer
O51LD

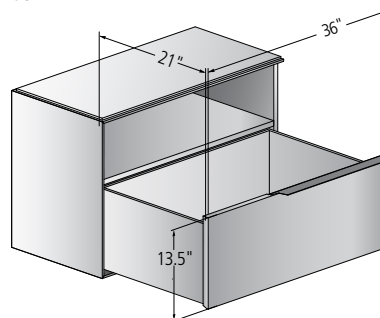

Center Box / Open
O51LO

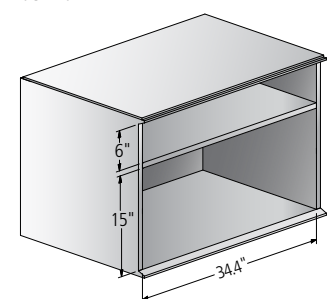



STEP 6: CASE CONFIGURATION

CONFERENCE HEIGHT WITH PLINTH BASE
BUFFET HEIGHT WITH METAL BASE

Select configuration and desired components for each cabinet location. **Defaults to Double Doors with Adjustable Height Shelves in all locations, if none selected.**

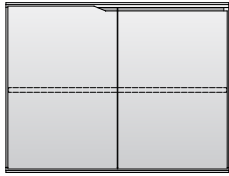

DOUBLE DOOR

- Includes adjustable shelf behind double doors
- Available on all credenzas

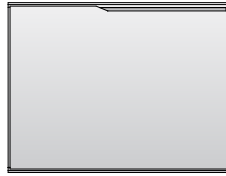

PULL OUT SINGLE DOOR

- 36" pull-out door front
- Available with pull-out waste/recycling or drawer refrigerator on 24.5"-depth credenzas

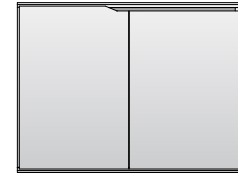

SEAMED PULL-OUT SINGLE DOOR

- Center seamed vertical accent on door front to match double doors
- 36" pull-out door front
- Available with pull-out waste/recycling or drawer refrigerator on 24.5"-depth credenzas

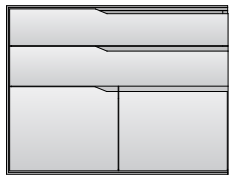

TWO BOX DRAWERS / DOUBLE DOORS

- Includes Knoll Felt, Pewter drawer liners; additional Knoll Felt or Brisa® UltraFabrics® drawer liner inserts available
- 13.5" -height doors
- White melamine drawer box construction and undermount soft closing glides
- Available on all credenzas

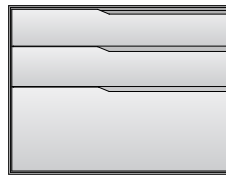

TWO BOX DRAWERS / LARGE BOX DRAWER

- Includes Knoll Felt, Pewter drawer liners; additional Knoll Felt or Brisa® UltraFabrics® drawer liner inserts available
- 36" large box drawer below
- White melamine drawer box construction and undermount soft closing glides
- Available on all credenzas

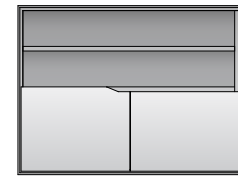

CENTER TWO BOX / DOUBLE DOORS

- Includes adjustable shelf behind double doors
- Available on 108" credenzas
- 13.5" -height doors

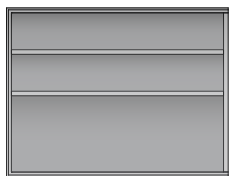

CENTER TWO BOX / OPEN

- Open shelf storage includes a single adjustable height shelf
- Available on 108" credenzas

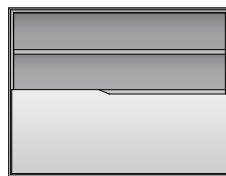

CENTER TWO BOX / LARGE BOX DRAWER

- 36" large box drawer below
- Available on 108" credenzas

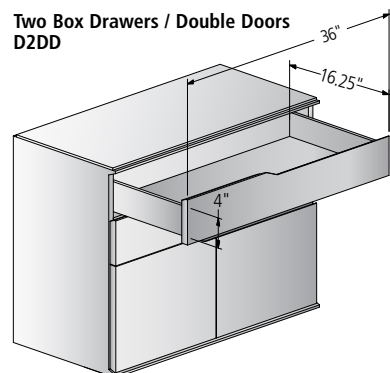

Two Box Drawers / Double Doors
D2DD

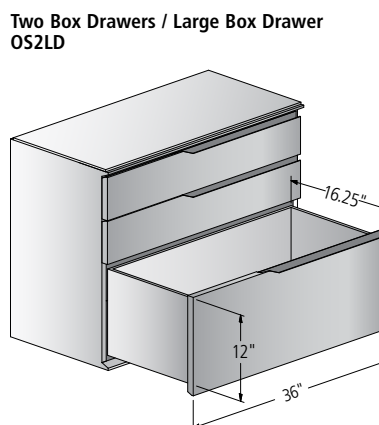

Two Box Drawers / Large Box Drawer
OS2LD

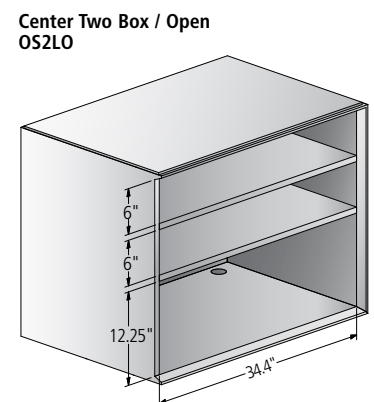

Center Two Box / Open
OS2LO



COMPONENTS

Specify Components within Case Option, if desired. Components include pull out waste/recycling, drawer refrigerator, charging drawers or equipment racks and trays.

RACKED EQUIPMENT AND VENTILATION CUTOUTS

- Select from sliding or fixed equipment racks
- Available on all 24.5"-depth cases; located behind any Double Door case option
- Low Height with Plinth Base and Conference Height with Metal Base - equipment racks hold 10 Rack Units (RU)
- Conference Height with Plinth Base and Buffet Height with Metal Base - equipment racks hold 12 Rack Units (RU)
- Equipment racks include a thermostatically-controlled fan and two cutouts:
 - Cables can be routed into case through a 2" grommet in the bottom panel
 - Round cutout in back panel accommodates a fan that activates automatically at 87° F and turns off when the ambient temperature in the cabinet reaches 85° F

WASTE AND RECYCLING

- A 36"-wide front-opening double waste bin system is available in all 24.5"-depth credenzas
- Low Height with Plinth Base and Conference Height with Metal Base - Bin Size: (2) 36 Qt.
- Conference Height with Plinth Base and Buffet Height with Metal base - Bin Size: (2) 41 Qt.
- Located behind Pull-out or Seamed Pull-out Single Door case option

REFRIGERATOR DRAWER

- Available in 24.5"-depth, Conference Height with Plinth Base and Buffet Height with Metal Base Credenzas
- Located behind Pull-out or Seamed Pull-out Single Door case option
- 3.1 cu ft storage capacity
- Five different temperature modes: fridge, freezer, pantry, chill, and wine
- Grain-matched drawer fronts
- Ventilation cutout in front of bottom panel
- Drawer refrigerator packaged separately. Some installation required.

CHARGING DRAWER

- Includes (2) Simplexes, (2) Dual USB-A, and (2) Qi wireless charging locations
- 120V
- 120" cord
- Tamper resistant
- UL Listed
- Includes Knoll Felt, Pewter drawer liners; additional Knoll Felt or Brisa® UltraFabrics® drawer liner insert available

PULL-OUT EQUIPMENT TRAY

- Available on all credenzas; located behind any Double Door case option
- Double Door includes adjustable shelving

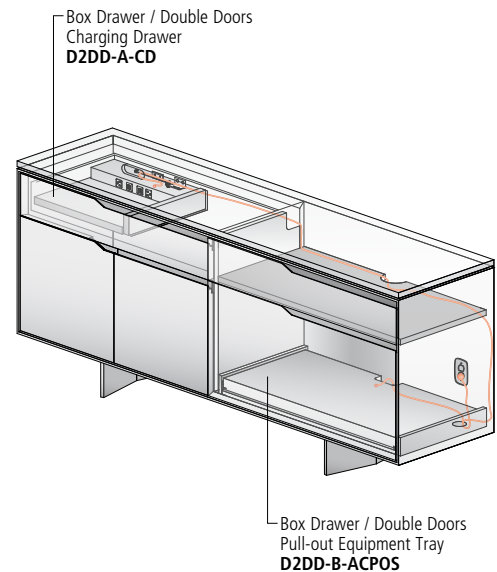
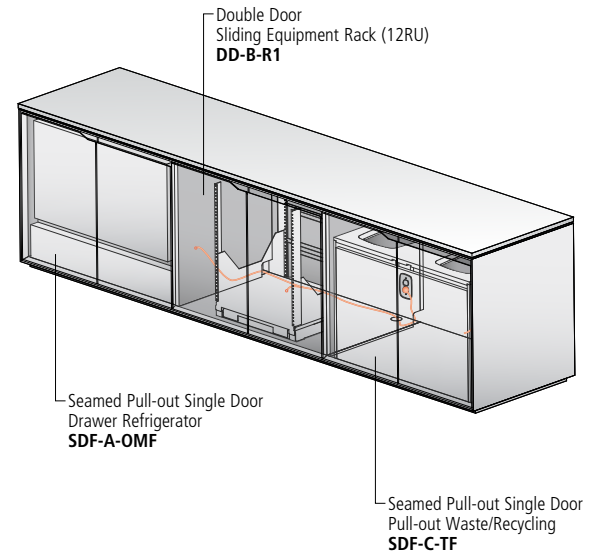



COMPONENT DIMENSIONS

2" Grommet in Bottom Panel Cutout

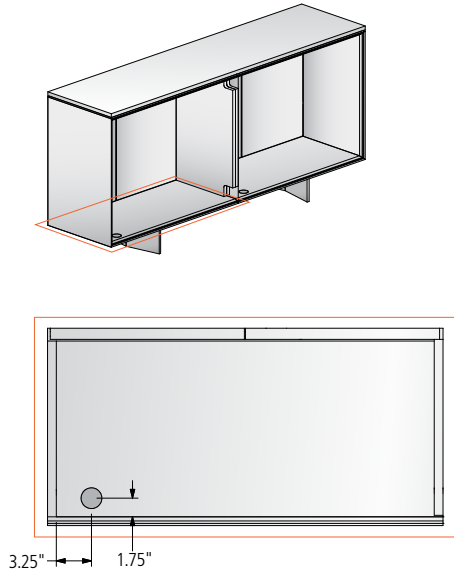

Thermostatically-Controlled Fan Cutout in Back Panel

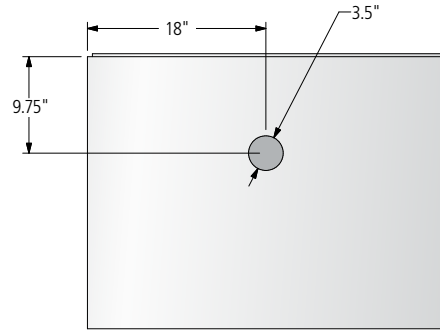

Charging Drawer

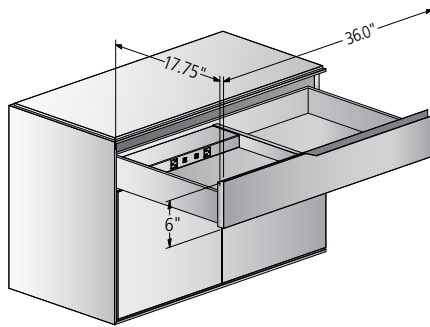

Pull-Out Equipment Tray

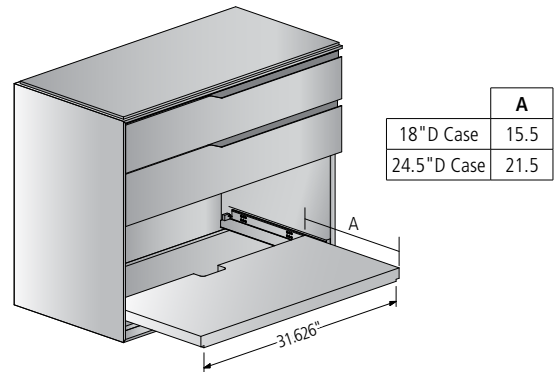

Refrigerator Drawer

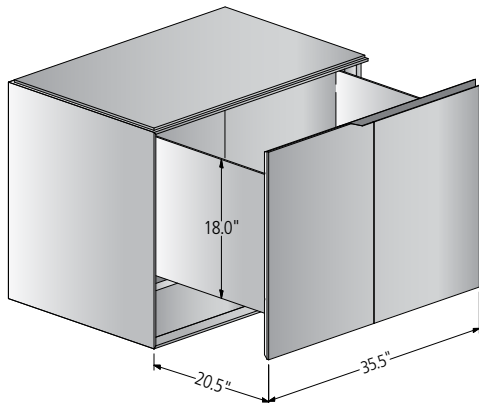

Waste/Recycling

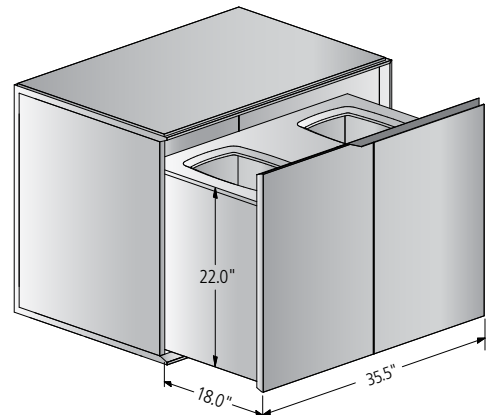



STEP 7: ACCESSORIES

Choose from drawer organizers and peg board systems available in three wood finishes. Fabric drawer liners, additional pencil trays, pull-out equipment trays, or plug strips may also be specified

DRAWER LINER INSERTS

- All box drawers includes Knoll Felt, Pewter drawer liner inserts. Alternate Knoll Felt or Brisa® UltraFabrics® drawer liner inserts available.

PENCIL TRAY

- Solid wood core frame and front rail
- Pencil drawer bottoms include Knoll Felt drawer liners; alternate Knoll Felt or Brisa® UltraFabrics® drawer liner inserts available
- Drawer dividers are polished aluminum (dividers are adjustable)

Pencil Tray

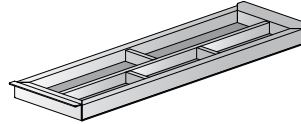

Pencil Tray Top View

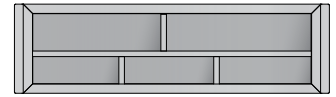

POWER PLUG STRIP

- 15 amps - mounts into case
- Includes (7) outlets, surge protection and 12' electrical cord

Power Plug Strip

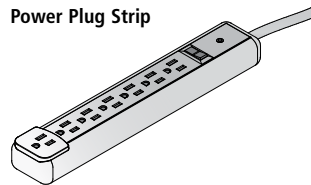

DRAWER ORGANIZER

- Can be inserted in any box drawer
- Ideal for office or utensil drawer organization
- Includes removable divider
- Can be arranged as needed for a variety of applications
- Constructed of wood; available in birch, walnut, or ash
- Includes:
 - (1) 36" depth extender
 - (1) cutlery organizer with (5) compartments
 - (4) small 4-1/8" x 11-13/16" drawer organizer boxes
 - (3) connection clips
 - (2) diagonal metal dividers for small organizer boxes

Drawer Organizer

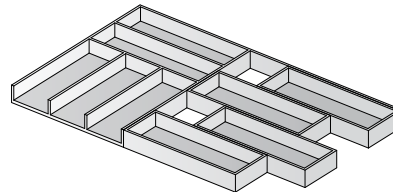

Peg Board System

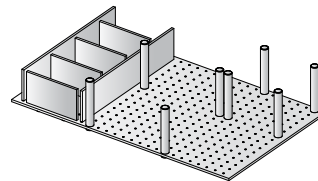

PEG BOARD SYSTEM

- Can be inserted in any large box drawer
- Can be quickly rearranged to adjust to storage needs
- Ideal for plates, bowls, and glassware
- Constructed of wood; available in birch, walnut, or ash
- Includes:
 - (1) perforated panel
 - (8) pegs for peg system
 - (2) long dividers
 - (4) short dividers

Pull-out Equipment Tray Retro Fit Kit

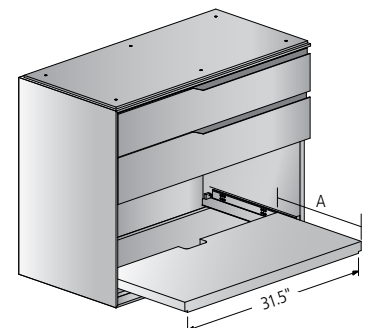
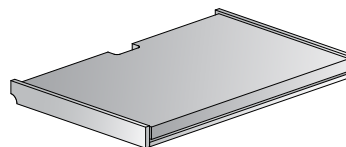

PULL-OUT EQUIPMENT TRAY RETRO FIT KIT

- Available on all credenzas; located behind any double door case option



LOW HEIGHT WITH PLINTH BASE

MODEL NUMBER: ACLC-7225

STEP 1: CASE STYLE

MUST SPECIFY

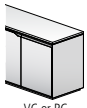

VC or PC



BVC or BPC

STANDARD CASE		STARTING PRICE
VC	18" D Veneer Case	7,170
PC	18" D Painted Case	6,657

BEVELED CASE		STARTING PRICE
BVC	18" D Veneer Case	9,750
BPC	18" D Painted Case	9,053

STEP 2: TOP MATERIAL AND EDGE PROFILE

MUST SPECIFY



Square Edge



2" Square Edge



Chamfer Edge

TOP WITH SQUARE EDGE		VC / PC	BVC / BPC
P	3/4" Laminate with Hardwood Edge	+1,502	+2,045
PE	3/4" Laminate with ABS Edge	+1,731	+2,178
XE	3/4" Fenix with ABS Edge	+2,002	+2,541
V	3/4" Veneer with Hardwood Edge	+2,180	+2,966
X	3/4" Fenix with Hardwood Edge	+2,886	+3,924
GG	3/8" Gloss Glass	+3,687	+5,016
2V	2" Veneer with Hardwood Edge	+4,267	+5,431
SG	3/8" Satin Glass	+4,597	+5,920
S	2cm Stone	+5,703	+7,758

TOP WITH CHAMFER EDGE		VC / PC	BVC / BPC
CV	3/4" Veneer	+2,886	+3,924
CS	2cm Stone	+6,383	+8,682

STEP 3: DOOR/DRAWER STYLE

Defaults to match case, if none selected

PAD	Painted	No Charge
HD	Horizontal Veneer	No Charge
VD	Vertical Veneer	No Charge
PWD	Plank Veneer	+302

STEP 4: PULL STYLE

MUST SPECIFY



Integrated Pull



Metal Tab Pull



Handle Pull

INTEGRATED PULL		
MIP	Powder Coat	No Charge
CAIP	Clear Anodized	No Charge
PCIP-72	Polished Chrome	+293

OPTIONS	CODE	PRICE
Wood Accent	Add WIP-72	+228

METAL TAB PULL		
MP	Powder Coat	No Charge
CAMP	Clear Anodized	No Charge
PCMP-72	Polished Chrome	+550

HANDLE PULL		
HP-72	Powder Coat	+560
CAHP-72	Clear Anodized	+560
PCHP-72	Polished Chrome	+716

STEP 5: HARDWARE OPTIONS

LOCKS		
L	Door Locks	+270

RAISED BACKSTOP		
RB-72	Powder Coat	+482
CARB-72	Clear Anodized	+482
APSRB-72	Polished Stainless	+1,720

REVEAL		
MR-7218	Powder Coat	+892
CAMR-7218	Clear Anodized	+892
APSMR-7218	Polished Stainless	+1,184

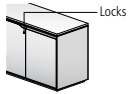

Locks

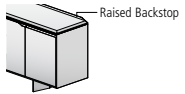

Raised Backstop

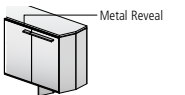

Metal Reveal

STEP 6: CASE CONFIGURATION

Defaults to Double Doors with Adjustable Height Shelves in all locations, if none selected.

[] Select configuration and desired components for each cabinet location.

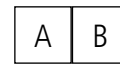

DD-[]	DOUBLE DOOR (DEFAULT)	No Charge
Add ACPOS-18	Pull-out Equipment Tray	+1,003



DD-[]

D1DD-[]	BOX DRAWER/DOUBLE DOORS	+615
Add CD	Charging Drawer	+2,343
Add ACPOS-18	Pull-out Equipment Tray	+1,003



D1DD-[]

D1LD-[]	BOX DRAWER/LARGE BOX DRAWER	+1,356
Add CD	Charging Drawer	+2,343



D1LD-[]



LOW HEIGHT WITH PLINTH BASE

MODEL NUMBER: ACLD-7225

STEP 1: CASE STYLE

MUST SPECIFY

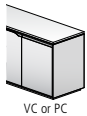

VC or PC



BVC or BPC

STANDARD CASE		STARTING PRICE
VC	24.5"D Veneer Case	7,878
PC	24.5"D Painted Case	7,315

BEVELED CASE		STARTING PRICE
BVC	24.5"D Veneer Case	10,713
BPC	24.5"D Painted Case	9,947

STEP 2: TOP MATERIAL AND EDGE PROFILE

MUST SPECIFY



Square Edge



2" Square Edge



Chamfer Edge

TOP WITH SQUARE EDGE		VC / PC	BVC / BPC
P	3/4" Laminate with Hardwood Edge	+1,584	+2,155
PE	3/4" Laminate with ABS Edge	+1,675	+2,328
XE	3/4" Fenix with ABS Edge	+2,789	+3,806
V	3/4" Veneer with Hardwood Edge	+2,111	+3,045
X	3/4" Fenix with Hardwood Edge	+2,927	+3,981
GG	3/8" Gloss Glass	+3,799	+5,168
ZV	2" Veneer with Hardwood Edge	+4,446	+5,759
SG	3/8" Satin Glass	+4,906	+6,045
S	2cm Stone	+6,053	+8,231

TOP WITH CHAMFER EDGE		VC / PC	BVC / BPC
CV	3/4" Veneer	+2,927	+4,100
CS	2cm Stone	+6,832	+9,291

STEP 3: DOOR/DRAWER STYLE

Defaults to match case, if none selected

PAD	Painted	No Charge
HD	Horizontal Veneer	No Charge
VD	Vertical Veneer	No Charge
PWD	Plank Veneer	+302

STEP 4: PULL STYLE

MUST SPECIFY



Integrated Pull



Metal Tab Pull



Handle Pull

INTEGRATED PULL		
MIP	Powder Coat	No Charge
CAIP	Clear Anodized	No Charge
PCIP-72	Polished Chrome	+293

OPTIONS	CODE	PRICE
Wood Accent	Add WIP-72	+228

METAL TAB PULL		
MP	Powder Coat	No Charge
CAMP	Clear Anodized	No Charge
PCMP-72	Polished Chrome	+550

HANDLE PULL		
HP-72	Powder Coat	+560
CAHP-72	Clear Anodized	+560
PCHP-72	Polished Chrome	+716

STEP 5: HARDWARE OPTIONS

LOCKS		
L	Door Locks	+270

RAISED BACKSTOP		
RB-72	Powder Coat	+482
CARB-72	Clear Anodized	+482
APSRB-72	Polished Stainless	+1,720

REVEAL		
MR-7224	Powder Coat	+909
CAMR-7224	Clear Anodized	+909
APSMR-7224	Polished Stainless	+1,226

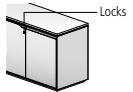

Locks

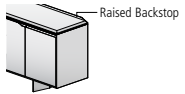

Raised Backstop

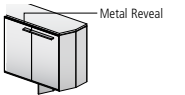

Metal Reveal

STEP 6: CASE CONFIGURATION

Defaults to Double Doors with Adjustable Height Shelves in all locations, if none selected.

[] Select configuration and desired components for each cabinet location.

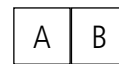

DD-[]	DOUBLE DOOR (DEFAULT)	No Charge
Add ACPOS-24	Pull-out Equipment Tray	+1,003
Add R2	Fixed Equipment Rack (10RU)	+836
Add R1	Sliding Equipment Rack (10RU)	+2,746



DD-1

PULL OUT SINGLE DOOR		
SD-[]-TF	Pull Out Waste/Recycling	+1,248



SD-1

SEAMED PULL-OUT SINGLE DOOR		
SDF-[]-TF	Pull Out Waste/Recycling	+1,248



SDF-1

D1DD-[]	BOX DRAWER/DOUBLE DOORS	+615
Add CD	Charging Drawer	+2,343
Add ACPOS-24	Pull-out Equipment Tray	+1,003



D1DD-1

D1LD-[]	BOX DRAWER/LARGE BOX DRAWER	+1,356
Add CD	Charging Drawer	+2,343



D1LD-1

STEP 7: ACCESSORIES

See page 36 for additional accessories

BOX DRAWER ORGANIZER		
ACBO-24-W	24.5"D Walnut Organizer	+915
ACBO-24-B	24.5"D Birch Organizer	+512
ACBO-24-A	24.5"D Ash Organizer	+915



BOX DRAWER ORGANIZER

LARGE BOX DRAWER PEG BOARD SYSTEM		
ACFO-24-W	24.5"D Walnut Peg Board System	+1,398
ACFO-24-B	24.5"D Birch Peg Board System	+742
ACFO-24-A	24.5"D Ash Peg Board System	+1,165



PEG BOARD SYSTEM



LOW HEIGHT WITH PLINTH BASE

MODEL NUMBER: ACLK-10825

STEP 1: CASE STYLE

MUST SPECIFY

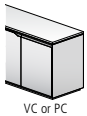

VC or PC



BVC or BPC

STANDARD CASE		STARTING PRICE
VC	18" D Veneer Case	8,532
PC	18" D Painted Case	7,923

BEVELED CASE		STARTING PRICE
BVC	18" D Veneer Case	11,050
BPC	18" D Painted Case	11,602

STEP 2: TOP MATERIAL AND EDGE PROFILE

MUST SPECIFY



Square Edge



2" Square Edge



Chamfer Edge

TOP WITH SQUARE EDGE		VC / PC	BVC / BPC
P	3/4" Laminate with Hardwood Edge	+1,788	+2,433
PE	3/4" Laminate with ABS Edge	+1,591	+2,226
XE	3/4" Fenix with ABS Edge	+1,877	+2,649
V	3/4" Veneer with Hardwood Edge	+2,594	+3,530
X	3/4" Fenix with Hardwood Edge	+3,434	+4,670
GG	3/8" Gloss Glass	+4,387	+5,968
2V	2" Veneer with Hardwood Edge	+5,076	+6,463
SG	3/8" Satin Glass	+5,471	+7,045
S	2cm Stone	+6,938	+9,437

TOP WITH CHAMFER EDGE		VC / PC	BVC / BPC
CV	3/4" Veneer	+3,434	+4,670
CS	2cm Stone	+7,756	+10,548

STEP 3: DOOR/DRAWER STYLE

Defaults to match case, if none selected

PAD	Painted	No Charge
HD	Horizontal Veneer	No Charge
VD	Vertical Veneer	No Charge
PWD	Plank Veneer	+302

STEP 4: PULL STYLE

MUST SPECIFY



Integrated Pull



Metal Tab Pull



Handle Pull

INTEGRATED PULL		
MIP	Powder Coat	No Charge
CAIP	Clear Anodized	No Charge
PCIP-108	Polished Chrome	+439

OPTIONS	CODE	PRICE
Wood Accent	Add WIP-108	+342

METAL TAB PULL		
MP	Powder Coat	No Charge
CAMP	Clear Anodized	No Charge
PCMP-108	Polished Chrome	+826

HANDLE PULL		
HP-108	Powder Coat	+841
CAHP-108	Clear Anodized	+841
PCHP-108	Polished Chrome	+1,073

STEP 5: HARDWARE OPTIONS

LOCKS		
L	Door Locks	+270

RAISED BACKSTOP		
RB-108	Powder Coat	+545
CARB-108	Clear Anodized	+545
APSRB-108	Polished Stainless	+1,973

REVEAL		
MR-10818	Powder Coat	+941
CAMR-10818	Clear Anodized	+941
APSMR-10818	Polished Stainless	+1,311

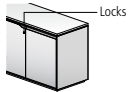

Locks

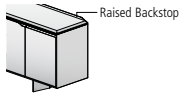

Raised Backstop

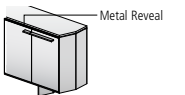

Metal Reveal

STEP 6: CASE CONFIGURATION

Defaults to Double Doors with Adjustable Height Shelves in all locations, if none selected.

[] Select configuration and desired components for each cabinet location.

A	B	C
---	---	---

DD-[]	DOUBLE DOOR (DEFAULT)	No Charge
Add ACPOS-18	Pull-out Equipment Tray	+1,003



DD-[]

D1DD-[]	BOX DRAWER/DOUBLE DOORS	+615
Add CD	Charging Drawer	+2,343
Add ACPOS-18	Pull-out Equipment Tray	+1,003



D1DD-[]

D1LD-[]	BOX DRAWER/LARGE BOX DRAWER	+1,356
Add CD	Charging Drawer	+2,343



D1LD-[]

OS1DD-B	CENTER BOX/DOUBLE DOORS	No Charge
Add ACPOS-18	Pull-out Equipment Tray	+1,003



OS1DD-B

OS1LD-B	CENTER BOX/LARGE BOX DRAWER	+742
---------	------------------------------------	------



OS1LD-B

OS1LO-B	CENTER BOX/OPEN SHELVES	No Charge
---------	--------------------------------	-----------



OS1LO-B



LOW HEIGHT WITH PLINTH BASE

MODEL NUMBER: **ACLD-10825**

STEP 1: CASE STYLE MUST SPECIFY

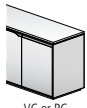

VC or PC



BVC or BPC

STANDARD CASE		STARTING PRICE
VC	24.5"D Veneer Case	9,375
PC	24.5"D Painted Case	8,705

BEVELED CASE		STARTING PRICE
BVC	24.5"D Veneer Case	12,749
BPC	24.5"D Painted Case	11,838

STEP 2: TOP MATERIAL AND EDGE PROFILE MUST SPECIFY



Square Edge



2" Square Edge



Chamfer Edge

TOP WITH SQUARE EDGE		VC / PC	BVC / BPC
P	3/4" Laminate with Hardwood Edge	+1,884	+2,564
PE	3/4" Laminate with ABS Edge	+1,722	+2,372
XE	3/4" Fenix with ABS Edge	+2,994	+4,086
V	3/4" Veneer with Hardwood Edge	+2,514	+3,420
X	3/4" Fenix with Hardwood Edge	+3,482	+4,736
GG	3/8" Gloss Glass	+4,520	+6,146
2V	2" Veneer with Hardwood Edge	+5,289	+6,808
SG	3/8" Satin Glass	+5,837	+7,192
S	2cm Stone	+7,374	+10,029

TOP WITH CHAMFER EDGE		VC / PC	BVC / BPC
CV	3/4" Veneer	+3,482	+4,736
CS	2cm Stone	+8,310	+11,302

STEP 3: DOOR/DRAWER STYLE

Defaults to match case, if none selected

PAD	Painted	No Charge
HD	Horizontal Veneer	No Charge
VD	Vertical Veneer	No Charge
PWD	Plank Veneer	+302

STEP 4: PULL STYLE MUST SPECIFY



Integrated Pull



Metal Tab Pull



Handle Pull

INTEGRATED PULL		
MIP	Powder Coat	No Charge
CAIP	Clear Anodized	No Charge
PCIP-108	Polished Chrome	+439

OPTIONS	CODE	PRICE
Wood Accent	Add WIP-108	+342

METAL TAB PULL		
MP	Powder Coat	No Charge
CAMP	Clear Anodized	No Charge
PCMP-108	Polished Chrome	+826

HANDLE PULL		
HP-108	Powder Coat	+841
CAHP-108	Clear Anodized	+841
PCHP-108	Polished Chrome	+1,073

STEP 5: HARDWARE OPTIONS

LOCKS		
L	Door Locks	+270

RAISED BACKSTOP		
RB-108	Powder Coat	+545
CARB-108	Clear Anodized	+545
APSRB-108	Polished Stainless	+1,973

REVEAL		
MR-10824	Powder Coat	+957
CAMR-10824	Clear Anodized	+957
APSMR-10824	Polished Stainless	+1,353

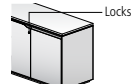

Locks

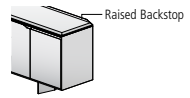

Raised Backstop

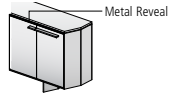

Metal Reveal

STEP 6: CASE CONFIGURATION

Defaults to Double Doors with Adjustable Height Shelves in all locations, if none selected.

[] Select configuration and desired components for each cabinet location.

A	B	C
---	---	---

DD-[]	DOUBLE DOOR (DEFAULT)	No Charge
Add ACPOS-24	Pull-out Equipment Tray	+1,003
Add R2	Fixed Equipment Rack (10RU)	+836
Add R1	Sliding Equipment Rack (10RU)	+2,746

SD-[]-TF	PULL OUT SINGLE DOOR	
	Pull Out Waste/Recycling	+1,248

SDF-[]-TF	SEAMED PULL-OUT SINGLE DOOR	
	Pull Out Waste/Recycling	+1,248

D1DD-[]	BOX DRAWER/DOUBLE DOORS	+615
Add CD	Charging Drawer	+2,343
Add ACPOS-24	Pull-out Equipment Tray	+1,003

D1LD-[]	BOX DRAWER/LARGE BOX DRAWER	+1,356
Add CD	Charging Drawer	+2,343

OS1DD-B	CENTER BOX/DOUBLE DOORS	No Charge
Add ACPOS-24	Pull-out Equipment Tray	+1,003

OS1LD-B	CENTER BOX/LARGE BOX DRAWER	+742
---------	------------------------------------	------

OS1LO-B	CENTER BOX/OPEN SHELVES	No Charge
---------	--------------------------------	-----------



DD-[]



SD-[]-TF



SDF-[]-TF



D1DD-[]



D1LD-[]



OS1DD-B



OS1LD-B



OS1LO-B

STEP 7: ACCESSORIES

See page 36 for additional accessories

BOX DRAWER ORGANIZER		
ACBO-24-W	24.5"D Walnut Organizer	+915
ACBO-24-B	24.5"D Birch Organizer	+512
ACBO-24-A	24.5"D Ash Organizer	+915



BOX DRAWER ORGANIZER

LARGE BOX DRAWER PEG BOARD SYSTEM		
ACFO-24-W	24.5"D Walnut Peg Board System	+1,398
ACFO-24-B	24.5"D Birch Peg Board System	+742
ACFO-24-A	24.5"D Ash Peg Board System	+1,165

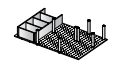

PEG BOARD SYSTEM



CONFERENCE HEIGHT WITH METAL BASE

MODEL NUMBER: ACLC-7230

STEP 1: CASE STYLE

MUST SPECIFY

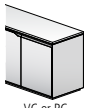

VC or PC



BVC or BPC

STANDARD CASE		STARTING PRICE
VC	18" D Veneer Case	7,887
PC	18" D Painted Case	7,420

BEVELED CASE		STARTING PRICE
BVC	18" D Veneer Case	10,725
BPC	18" D Painted Case	9,958

STEP 2: TOP MATERIAL AND EDGE PROFILE

MUST SPECIFY



Square Edge



2" Square Edge



Chamfer Edge

TOP WITH SQUARE EDGE		VC / PC	BVC / BPC
P	3/4" Laminate with Hardwood Edge	+1,502	+2,045
PE	3/4" Laminate with ABS Edge	+1,731	+2,178
XE	3/4" Fenix with ABS Edge	+2,002	+2,541
V	3/4" Veneer with Hardwood Edge	+2,180	+2,966
X	3/4" Veneer with Hardwood Edge	+2,886	+3,924
GG	3/8" Gloss Glass	+3,687	+5,016
2V	2" Veneer with Hardwood Edge	+4,267	+5,431
SG	3/8" Satin Glass	+4,597	+5,920
S	2cm Stone	+5,703	+7,758

TOP WITH CHAMFER EDGE		VC / PC	BVC / BPC
CV	3/4" Veneer	+2,886	+3,924
CS	2cm Stone	+6,383	+8,682

STEP 3: DOOR/DRAWER STYLE

Defaults to match case, if none selected

PAD	Painted	No Charge
HD	Horizontal Veneer	No Charge
VD	Vertical Veneer	No Charge
PWD	Plank Veneer	+302

STEP 4: PULL STYLE

MUST SPECIFY



Integrated Pull



Metal Tab Pull



Handle Pull

INTEGRATED PULL		
MIP	Powder Coat	No Charge
CAIP	Clear Anodized	No Charge
PCIP-72	Polished Chrome	+293

OPTIONS	CODE	PRICE
Wood Accent	Add WIP-72	+228

METAL TAB PULL		
MP	Powder Coat	No Charge
CAMP	Clear Anodized	No Charge
PCMP-72	Polished Chrome	+550

HANDLE PULL		
HP-72	Powder Coat	+560
CAHP-72	Clear Anodized	+560
PCHP-72	Polished Chrome	+716

STEP 5: HARDWARE OPTIONS

LOCKS		
L	Door Locks	+270

METAL BASE OPTIONS Defaults to Powder Coat, if none selected		
PCMB	Polished Chrome	+405

RAISED BACKSTOP		
RB-72	Powder Coat	+482
CARB-72	Clear Anodized	+482
APSRB-72	Polished Stainless	+1,720

REVEAL		
MR-7218	Powder Coat	+892
CAMR-7218	Clear Anodized	+892
APSMR-7218	Polished Stainless	+1,184

STEP 6: CASE CONFIGURATION

Defaults to Double Doors with Adjustable Height Shelves in all locations, if none selected

[] Select configuration and desired components for each cabinet location.

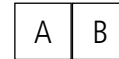

DD-[]	DOUBLE DOOR (DEFAULT)	No Charge
Add ACPOS-18	Pull-out Equipment Tray	+1,003

D1DD-[]	BOX DRAWER/DOUBLE DOORS	+615
Add CD	Charging Drawer	+2,343
Add ACPOS-18	Pull-out Equipment Tray	+1,003

D1LD-[]	BOX DRAWER/LARGE BOX DRAWER	+1,356
Add CD	Charging Drawer	+2,343

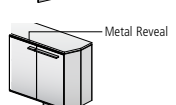
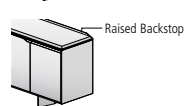
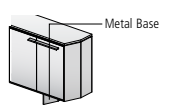
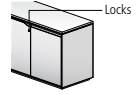



CONFERENCE HEIGHT WITH METAL BASE

MODEL NUMBER: ACLD-7230

STEP 1: CASE STYLE

MUST SPECIFY

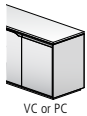

VC or PC



BVC or BPC

STANDARD CASE		STARTING PRICE
VC	24.5"D Veneer Case	8,666
PC	24.5"D Painted Case	8,153

BEVELED CASE		STARTING PRICE
BVC	24.5"D Veneer Case	11,784
BPC	24.5"D Painted Case	10,941

STEP 2: TOP MATERIAL AND EDGE PROFILE

MUST SPECIFY



Square Edge



2" Square Edge



Chamfer Edge

TOP WITH SQUARE EDGE		VC / PC	BVC / BPC
P	3/4" Laminate with Hardwood Edge	+1,584	+2,155
PE	3/4" Laminate with ABS Edge	+1,675	+2,328
XE	3/4" Fenix with ABS Edge	+2,789	+3,806
V	3/4" Veneer with Hardwood Edge	+2,111	+3,045
X	3/4" Fenix with Hardwood Edge	+2,927	+3,981
GG	3/8" Gloss Glass	+3,799	+5,168
2V	2" Veneer with Hardwood Edge	+4,446	+5,759
SG	3/8" Satin Glass	+4,906	+6,045
S	2cm Stone	+6,053	+8,231

TOP WITH CHAMFER EDGE		VC / PC	BVC / BPC
CV	3/4" Veneer	+2,927	+4,100
CS	2cm Stone	+6,832	+9,291

STEP 3: DOOR/DRAWER STYLE

Defaults to match case, if none selected

PAD	Painted	No Charge
HD	Horizontal Veneer	No Charge
VD	Vertical Veneer	No Charge
PWD	Plank Veneer	+302

STEP 4: PULL STYLE

MUST SPECIFY



Integrated Pull



Metal Tab Pull



Handle Pull

INTEGRATED PULL		
MIP	Powder Coat	No Charge
CAIP	Clear Anodized	No Charge
PCIP-72	Polished Chrome	+293

OPTIONS	CODE	PRICE
Wood Accent	Add WIP-72	+228

METAL TAB PULL		
MP	Powder Coat	No Charge
CAMP	Clear Anodized	No Charge
PCMP-72	Polished Chrome	+550

HANDLE PULL		
HP-72	Powder Coat	+560
CAHP-72	Clear Anodized	+560
PCHP-72	Polished Chrome	+716

STEP 5: HARDWARE OPTIONS

LOCKS		
L	Door Locks	+270

METAL BASE OPTIONS Defaults to Powder Coat, if none selected		
PCMB	Polished Chrome	+405

RAISED BACKSTOP		
RB-72	Powder Coat	+482
CARB-72	Clear Anodized	+482
APSRB-72	Polished Stainless	+1,720

REVEAL		
MR-7224	Powder Coat	+909
CAMR-7224	Clear Anodized	+909
APSMR-7224	Polished Stainless	+1,226

STEP 6: CASE CONFIGURATION

Defaults to Double Doors with Adjustable Height Shelves in all locations, if none selected.

[] Select configuration and desired components for each cabinet location.



DD-[]	DOUBLE DOOR (DEFAULT)	No Charge
Add ACPOS-24	Pull-out Equipment Tray	+1,003
Add R2	Fixed Equipment Rack (10RU)	+836
Add R1	Sliding Equipment Rack (10RU)	+2,746

PULL OUT SINGLE DOOR		
SD-[]-TF	Pull Out Waste/Recycling	+1,248

SEAMED PULL-OUT SINGLE DOOR		
SDF-[]-TF	Pull Out Waste/Recycling	+1,248

D1DD-[]	BOX DRAWER/DOUBLE DOORS	+615
Add CD	Charging Drawer	+2,343
Add ACPOS-24	Pull-out Equipment Tray	+1,003

D1LD-[]	BOX DRAWER/LARGE BOX DRAWER	+1,356
Add CD	Charging Drawer	+2,343

STEP 7: ACCESSORIES

See page 36 for additional accessories

BOX DRAWER ORGANIZER		
ACBO-24-W	24.5"D Walnut Organizer	+915
ACBO-24-B	24.5"D Birch Organizer	+512
ACBO-24-A	24.5"D Ash Organizer	+915

LARGE BOX DRAWER PEG BOARD SYSTEM		
ACFO-24-W	24.5"D Walnut Peg Board System	+1,398
ACFO-24-B	24.5"D Birch Peg Board System	+742
ACFO-24-A	24.5"D Ash Peg Board System	+1,165

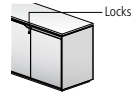

Locks

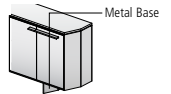

Metal Base

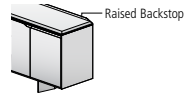

Raised Backstop

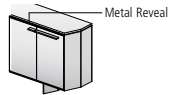

Metal Reveal



DD-1]



SD-1]-TF



SDF-1]-TF



D1DD-1]



D1LD-1]



BOX DRAWER ORGANIZER



PEG BOARD SYSTEM



CONFERENCE HEIGHT WITH METAL BASE

MODEL NUMBER: ACLC-10830

STEP 1: CASE STYLE

MUST SPECIFY

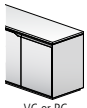

VC or PC



BVC or BPC

STANDARD CASE		STARTING PRICE
VC	18" D Veneer Case	9,384
PC	18" D Painted Case	8,830

BEVELED CASE		STARTING PRICE
BVC	18" D Veneer Case	12,762
BPC	18" D Painted Case	11,851

STEP 2: TOP MATERIAL AND EDGE PROFILE

MUST SPECIFY



Square Edge



2" Square Edge



Chamfer Edge

TOP WITH SQUARE EDGE		VC / PC	BVC / BPC
P	3/4" Laminate with Hardwood Edge	+1,788	+2,433
PE	3/4" Laminate with ABS Edge	+1,591	+2,226
XE	3/4" Fenix with ABS Edge	+1,877	+2,649
V	3/4" Veneer with Hardwood Edge	+2,594	+3,530
X	3/4" Fenix with Hardwood Edge	+3,434	+4,670
GG	3/8" Gloss Glass	+4,387	+5,968
2V	2" Veneer with Hardwood Edge	+5,076	+6,463
SG	3/8" Satin Glass	+5,471	+7,045
S	2cm Stone	+6,938	+9,437

TOP WITH CHAMFER EDGE		VC / PC	BVC / BPC
CV	3/4" Veneer	+3,434	+4,670
CS	2cm Stone	+7,756	+10,548

STEP 3: DOOR/DRAWER STYLE

Defaults to match case, if none selected

PAD	Painted	No Charge
HD	Horizontal Veneer	No Charge
VD	Vertical Veneer	No Charge
PWD	Plank Veneer	+302

STEP 4: PULL STYLE

MUST SPECIFY



Integrated Pull



Metal Tab Pull



Handle Pull

INTEGRATED PULL		
MIP	Powder Coat	No Charge
CAIP	Clear Anodized	No Charge
PCIP-108	Polished Chrome	+439

OPTIONS	CODE	PRICE
Wood Accent	Add WIP-108	+342

METAL TAB PULL		
MP	Powder Coat	No Charge
CAMP	Clear Anodized	No Charge
PCMP-108	Polished Chrome	+826

HANDLE PULL		
HP-108	Powder Coat	+841
CAHP-108	Clear Anodized	+841
PCHP-108	Polished Chrome	+1,073

STEP 5: HARDWARE OPTIONS

LOCKS		
L	Door Locks	+270

METAL BASE OPTIONS Defaults to Powder Coat, if none selected		
PCMB	Polished Chrome	+405

RAISED BACKSTOP		
RB-108	Powder Coat	+545
CARB-108	Clear Anodized	+545
APSRB-108	Polished Stainless	+1,973

REVEAL		
MR-10818	Powder Coat	+941
CAMR-10818	Clear Anodized	+941
APSMR-10818	Polished Stainless	+1,311

STEP 6: CASE CONFIGURATION

Defaults to Double Doors with Adjustable Height Shelves in all locations, if none selected.

[] Select configuration and desired components for each cabinet location.

A	B	C
---	---	---

DD-[]	DOUBLE DOOR (DEFAULT)	No Charge
Add ACPOS-18	Pull-out Equipment Tray	+1,003

D1DD-[]	BOX DRAWER/DOUBLE DOORS	+615
Add CD	Charging Drawer	+2,343
Add ACPOS-18	Pull-out Equipment Tray	+1,003

D1LD-[]	BOX DRAWER/LARGE BOX DRAWER	+1,356
Add CD	Charging Drawer	+2,343

OS1DD-B	CENTER BOX/DOUBLE DOORS	No Charge
Add ACPOS-18	Pull-out Equipment Tray	+1,003

OS1LD-B	CENTER BOX/LARGE BOX DRAWER	+742
---------	------------------------------------	------

OS1LO-B	CENTER BOX/OPEN SHELVES	No Charge
---------	--------------------------------	-----------

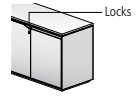

Locks

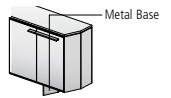

Metal Base

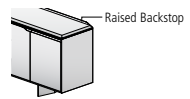

Raised Backstop

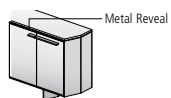

Metal Reveal



DD-1



D1DD-1



D1LD-1

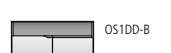

OS1DD-B



OS1LD-B



OS1LO-B



CONFERENCE HEIGHT WITH METAL BASE

MODEL NUMBER: ACLD-10830

STEP 1: CASE STYLE

MUST SPECIFY

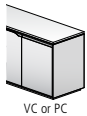

VC or PC



BVC or BPC

STANDARD CASE		STARTING PRICE
VC	24.5"D Veneer Case	10,311
PC	24.5"D Painted Case	9,701

BEVELED CASE		STARTING PRICE
BVC	24.5"D Veneer Case	14,023
BPC	24.5"D Painted Case	13,020

STEP 2: TOP MATERIAL AND EDGE PROFILE

MUST SPECIFY



Square Edge



2" Square Edge



Chamfer Edge

TOP WITH SQUARE EDGE		VC / PC	BVC / BPC
P	3/4" Laminate with Hardwood Edge	+1,884	+2,564
PE	3/4" Laminate with ABS Edge	+1,722	+2,372
XE	3/4" Fenix with ABS Edge	+2,994	+4,086
V	3/4" Veneer with Hardwood Edge	+2,514	+3,420
X	3/4" Veneer with Hardwood Edge	+3,482	+4,736
GG	3/8" Gloss Glass	+4,520	+6,146
2V	2" Veneer with Hardwood Edge	+5,289	+6,808
SG	3/8" Satin Glass	+5,837	+7,192
S	2cm Stone	+7,374	+10,029

TOP WITH CHAMFER EDGE		VC / PC	BVC / BPC
CV	3/4" Veneer	+3,482	+4,736
CS	2cm Stone	+8,310	+11,302

STEP 3: DOOR/DRAWER STYLE

Defaults to match case, if none selected

PAD	Painted	No Charge
HD	Horizontal Veneer	No Charge
VD	Vertical Veneer	No Charge
PWD	Plank Veneer	+302

STEP 4: PULL STYLE

MUST SPECIFY



Integrated Pull



Metal Tab Pull



Handle Pull

INTEGRATED PULL		
MIP	Powder Coat	No Charge
CAIP	Clear Anodized	No Charge
PCIP-108	Polished Chrome	+439

OPTIONS	CODE	PRICE
Wood Accent	Add WIP-108	+342

METAL TAB PULL		
MP	Powder Coat	No Charge
CAMP	Clear Anodized	No Charge
PCMP-108	Polished Chrome	+826

HANDLE PULL		
HP-108	Powder Coat	+841
CAHP-108	Clear Anodized	+841
PCHP-108	Polished Chrome	+1,073

STEP 5: HARDWARE OPTIONS

LOCKS		
L	Door Locks	+270

METAL BASE OPTIONS Defaults to Powder Coat, if none selected		
PCMB	Polished Chrome	+405

RAISED BACKSTOP		
RB-108	Powder Coat	+545
CARB-108	Clear Anodized	+545
APSRB-108	Polished Stainless	+1,973

REVEAL		
MR-10824	Powder Coat	+957
CAMR-10824	Clear Anodized	+957
APSMR-10824	Polished Stainless	+1,353

STEP 6: CASE CONFIGURATION

Defaults to Double Doors with Adjustable Height Shelves in all locations, if none selected.

[] Select configuration and desired components for each cabinet location.

A	B	C

DD-[]	DOUBLE DOOR (DEFAULT)	No Charge
Add ACPOS-24	Pull-out Equipment Tray	+1,003
Add R2	Fixed Equipment Rack (10RU)	+836
Add R1	Sliding Equipment Rack (10RU)	+2,746

SD-[]-TF	PULL OUT SINGLE DOOR	
	Pull Out Waste/Recycling	+1,248

SDF-[]-TF	SEAMED PULL-OUT SINGLE DOOR	
	Pull Out Waste/Recycling	+1,248

D1DD-[]	BOX DRAWER/DOUBLE DOORS	+615
Add CD	Charging Drawer	+2,343
Add ACPOS-24	Pull-out Equipment Tray	+1,003

D1LD-[]	BOX DRAWER/LARGE BOX DRAWER	+1,356
Add CD	Charging Drawer	+2,343

OS1DD-B	CENTER BOX/DOUBLE DOORS	No Charge
Add ACPOS-24	Pull-out Equipment Tray	+1,003

OS1LD-B	CENTER BOX/LARGE BOX DRAWER	+742
---------	------------------------------------	------

OS1LO-B	CENTER BOX/OPEN SHELVES	No Charge
---------	--------------------------------	-----------

STEP 7: ACCESSORIES

See page 36 for additional accessories

BOX DRAWER ORGANIZER		
ACBO-24-W	24.5"D Walnut Organizer	+915
ACBO-24-B	24.5"D Birch Organizer	+512
ACBO-24-A	24.5"D Ash Organizer	+915

LARGE BOX DRAWER PEG BOARD SYSTEM		
ACFO-24-W	24.5"D Walnut Peg Board System	+1,398
ACFO-24-B	24.5"D Birch Peg Board System	+742
ACFO-24-A	24.5"D Ash Peg Board System	+1,165

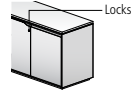

Locks

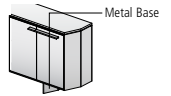

Metal Base

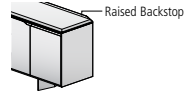

Raised Backstop

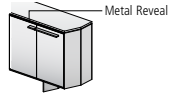

Metal Reveal



DD-[]



SD-[]-TF



SDF-[]-TF



D1DD-[]



D1LD-[]



OS1DD-B



OS1LD-B



OS1LO-B



BOX DRAWER ORGANIZER

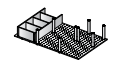

PEG BOARD SYSTEM



CONFERENCE HEIGHT WITH PLINTH BASE

MODEL NUMBER: ACCC-7230

STEP 1: CASE STYLE

MUST SPECIFY



VC or PC



BVC or BPC

STANDARD CASE		STARTING PRICE
VC	18" D Veneer Case	7,894
PC	18" D Painted Case	7,339

BEVELED CASE		STARTING PRICE
BVC	18" D Veneer Case	10,735
BPC	18" D Painted Case	9,968

STEP 2: TOP MATERIAL AND EDGE PROFILE

MUST SPECIFY



Square Edge



2" Square Edge



Chamfer Edge

TOP WITH SQUARE EDGE		VC / PC	BVC / BPC
P	3/4" Laminate with Hardwood Edge	+1,502	+2,045
PE	3/4" Laminate with ABS Edge	+1,731	+2,178
XE	3/4" Fenix with ABS Edge	+2,002	+2,541
V	3/4" Veneer with Hardwood Edge	+2,180	+2,966
X	3/4" Fenix with Hardwood Edge	+2,886	+3,924
GG	3/8" Gloss Glass	+3,687	+5,016
2V	2" Veneer with Hardwood Edge	+4,267	+5,431
SG	3/8" Satin Glass	+4,597	+5,920
S	2cm Stone	+5,703	+7,758

TOP WITH CHAMFER EDGE		VC / PC	BVC / BPC
CV	3/4" Veneer	+2,886	+3,924
CS	2cm Stone	+6,383	+8,682

STEP 3: DOOR/DRAWER STYLE

Defaults to match case, if none selected

PAD	Painted	No Charge
HD	Horizontal Veneer	No Charge
VD	Vertical Veneer	No Charge
PWD	Plank Veneer	+302

STEP 4: PULL STYLE

MUST SPECIFY



Integrated Pull



Metal Tab Pull



Handle Pull

INTEGRATED PULL		
MIP	Powder Coat	No Charge
CAIP	Clear Anodized	No Charge
PCIP-72	Polished Chrome	+293

OPTIONS	CODE	PRICE
Wood Accent	Add WIP-72	+228

METAL TAB PULL		
MP	Powder Coat	No Charge
CAMP	Clear Anodized	No Charge
PCMP-72	Polished Chrome	+550

HANDLE PULL		
HP-72	Powder Coat	+560
CAHP-72	Clear Anodized	+560
PCHP-72	Polished Chrome	+716

STEP 5: HARDWARE OPTIONS

LOCKS		
L	Door Locks	+270

RAISED BACKSTOP		
RB-72	Powder Coat	+482
CARB-72	Clear Anodized	+482
APSRB-72	Polished Stainless	+1,720

REVEAL		
MR-7218	Powder Coat	+892
CAMR-7218	Clear Anodized	+892
APSMR-7218	Polished Stainless	+1,184

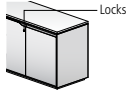

Locks

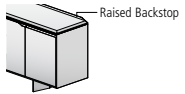

Raised Backstop

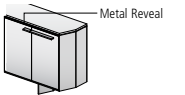

Metal Reveal

STEP 6: CASE CONFIGURATION

Defaults to Double Doors with Adjustable Height Shelves in all locations, if none selected

[] Select configuration and desired components for each cabinet location.



DD-[]	DOUBLE DOOR (DEFAULT)	No Charge
Add ACPOS-18	Pull-out Equipment Tray	+1,003

D2DD-[]	BOX DRAWER/DOUBLE DOORS	+1,229
Add CD	Charging Drawer	+2,343
Add ACPOS-18	Pull-out Equipment Tray	+1,003

D2LD-[]	BOX DRAWER/LARGE BOX DRAWER	+1,968
Add CD	Charging Drawer	+2,343



DD-1



D2DD-1



D2LD-1



CONFERENCE HEIGHT WITH PLINTH BASE

MODEL NUMBER: ACCD-7230

STEP 1: CASE STYLE

MUST SPECIFY

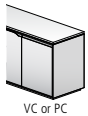

VC or PC



BVC or BPC

STANDARD CASE		STARTING PRICE
VC	24.5"D Veneer Case	8,673
PC	24.5"D Painted Case	8,063

BEVELED CASE		STARTING PRICE
BVC	24.5"D Veneer Case	11,795
BPC	24.5"D Painted Case	10,953

STEP 2: TOP MATERIAL AND EDGE PROFILE

MUST SPECIFY



Square Edge



2" Square Edge



Chamfer Edge

TOP WITH SQUARE EDGE		VC / PC	BVC / BPC
P	3/4" Laminate with Hardwood Edge	+1,584	+2,155
PE	3/4" Laminate with ABS Edge	+1,675	+2,328
XE	3/4" Fenix with ABS Edge	+2,789	+3,806
V	3/4" Veneer with Hardwood Edge	+2,111	+3,045
X	3/4" Fenix with Hardwood Edge	+2,927	+3,981
GG	3/8" Gloss Glass	+3,799	+5,168
2V	2" Veneer with Hardwood Edge	+4,446	+5,759
SG	3/8" Satin Glass	+4,906	+6,045
S	2cm Stone	+6,053	+8,231

TOP WITH CHAMFER EDGE		VC / PC	BVC / BPC
CV	3/4" Veneer	+2,927	+4,100
CS	2cm Stone	+6,832	+9,291

STEP 3: DOOR/DRAWER STYLE

Defaults to match case, if none selected

PAD	Painted	No Charge
HD	Horizontal Veneer	No Charge
VD	Vertical Veneer	No Charge
PWD	Plank Veneer	+302

STEP 4: PULL STYLE

MUST SPECIFY



Integrated Pull



Metal Tab Pull



Handle Pull

INTEGRATED PULL		
MIP	Powder Coat	No Charge
CAIP	Clear Anodized	No Charge
PCIP-72	Polished Chrome	+293

OPTIONS	CODE	PRICE
Wood Accent	Add WIP-72	+228

METAL TAB PULL		
MP	Powder Coat	No Charge
CAMP	Clear Anodized	No Charge
PCMP-72	Polished Chrome	+550

HANDLE PULL		
HP-72	Powder Coat	+560
CAHP-72	Clear Anodized	+560
PCHP-72	Polished Chrome	+716

STEP 5: HARDWARE OPTIONS

LOCKS		
L	Door Locks	+270

RAISED BACKSTOP		
RB-72	Powder Coat	+482
CARB-72	Clear Anodized	+482
APSRB-72	Polished Stainless	+1,720

REVEAL		
MR-7224	Powder Coat	+909
CAMR-7224	Clear Anodized	+909
APSMR-7224	Polished Stainless	+1,226

STEP 6: CASE CONFIGURATION

Defaults to Double Doors with Adjustable Height Shelves in all locations, if none selected

[] Select configuration and desired components for each cabinet location.

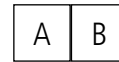

DD-[]	DOUBLE DOOR (DEFAULT)	No Charge
Add ACPOS-24	Pull-out Equipment Tray	+1,003
Add R2	Fixed Equipment Rack (12RU)	+836
Add R1	Sliding Equipment Rack (12RU)	+2,746

PULL OUT SINGLE DOOR		
SD-[]-TF	Pull Out Waste/Recycling	+1,248
SD-[]-OMF	Drawer Refrigerator	+10,370

SEAMED PULL-OUT SINGLE DOOR		
SDF-[]-TF	Pull Out Waste/Recycling	+1,248
SDF-[]-OMF	Drawer Refrigerator	+10,370

D2DD-[]	BOX DRAWER/DOUBLE DOORS	+1,229
Add CD	Charging Drawer	+2,343
Add ACPOS-24	Pull-out Equipment Tray	+1,003

D2LD-[]	BOX DRAWER/LARGE BOX DRAWER	+1,968
Add CD	Charging Drawer	+2,343

STEP 7: ACCESSORIES

See page 36 for additional accessories

BOX DRAWER ORGANIZER		
ACBO-24-W	24.5"D Walnut Organizer	+915
ACBO-24-B	24.5"D Birch Organizer	+512
ACBO-24-A	24.5"D Ash Organizer	+915

LARGE BOX DRAWER PEG BOARD SYSTEM		
ACFO-24-W	24.5"D Walnut Peg Board System	+1,398
ACFO-24-B	24.5"D Birch Peg Board System	+742
ACFO-24-A	24.5"D Ash Peg Board System	+1,165

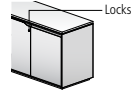

Locks

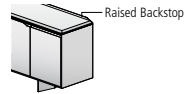

Raised Backstop

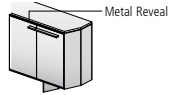

Metal Reveal

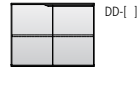

DD-1



SD-1

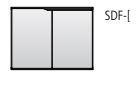

SDF-1



D2DD-1

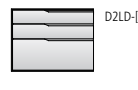

D2LD-1



BOX DRAWER ORGANIZER



PEG BOARD SYSTEM



CONFERENCE HEIGHT WITH PLINTH BASE

MODEL NUMBER: ACCC-10830

STEP 1: CASE STYLE

MUST SPECIFY



VC or PC



BVC or BPC

STANDARD CASE		STARTING PRICE
VC	18"D Veneer Case	9,395
PC	18"D Painted Case	8,733

BEVELED CASE		STARTING PRICE
BVC	18"D Veneer Case	12,775
BPC	18"D Painted Case	11,862

STEP 2: TOP MATERIAL AND EDGE PROFILE

MUST SPECIFY



Square Edge



2" Square Edge



Chamfer Edge

TOP WITH SQUARE EDGE		VC / PC	BVC / BPC
P	3/4" Laminate with Hardwood Edge	+1,788	+2,433
PE	3/4" Laminate with ABS Edge	+1,591	+2,226
XE	3/4" Fenix with ABS Edge	+1,877	+2,649
V	3/4" Veneer with Hardwood Edge	+2,594	+3,530
X	3/4" Fenix with Hardwood Edge	+3,434	+4,670
GG	3/8" Gloss Glass	+4,387	+5,968
2V	2" Veneer with Hardwood Edge	+5,076	+6,463
SG	3/8" Satin Glass	+5,471	+7,045
S	2cm Stone	+6,938	+9,437

TOP WITH CHAMFER EDGE		VC / PC	BVC / BPC
CV	3/4" Veneer	+3,434	+4,670
CS	2cm Stone	+7,756	+10,548

STEP 3: DOOR/DRAWER STYLE

Defaults to match case, if none selected

PAD	Painted	No Charge
HD	Horizontal Veneer	No Charge
VD	Vertical Veneer	No Charge
PWD	Plank Veneer	+302

STEP 4: PULL STYLE

MUST SPECIFY



Integrated Pull



Metal Tab Pull



Handle Pull

INTEGRATED PULL		
MIP	Powder Coat	No Charge
CAIP	Clear Anodized	No Charge
PCIP-108	Polished Chrome	+439

OPTIONS	CODE	PRICE
Wood Accent	Add WIP-108	+342

METAL TAB PULL		
MP	Powder Coat	No Charge
CAMP	Clear Anodized	No Charge
PCMP-108	Polished Chrome	+826

HANDLE PULL		
HP-108	Powder Coat	+841
CAHP-108	Clear Anodized	+841
PCHP-108	Polished Chrome	+1,073

STEP 5: HARDWARE OPTIONS

LOCKS		
L	Door Locks	+270

RAISED BACKSTOP		
RB-108	Powder Coat	+545
CARB-108	Clear Anodized	+545
APSRB-108	Polished Stainless	+1,973

REVEAL		
MR-10818	Powder Coat	+941
CAMR-10818	Clear Anodized	+941
APSMR-10818	Polished Stainless	+1,311

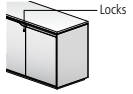

Locks

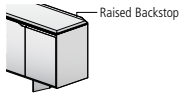

Raised Backstop

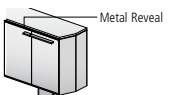

Metal Reveal

STEP 6: CASE CONFIGURATION

Defaults to Double Doors with Adjustable Height Shelves in all locations, if none selected

[] Select configuration and desired components for each cabinet location.

A	B	C
---	---	---

DD-[]	DOUBLE DOOR (DEFAULT)	No Charge
Add ACPOS-18	Pull-out Equipment Tray	+1,003



DD-1 |

D2DD-[]	BOX DRAWER/DOUBLE DOORS	+1,229
Add CD	Charging Drawer	+2,343
Add ACPOS-18	Pull-out Equipment Tray	+1,003



D2DD-1 |

D2LD-[]	BOX DRAWER/LARGE BOX DRAWER	+1,968
Add CD	Charging Drawer	+2,343



D2LD-1 |

OS2DD-B	CENTER BOX/DOUBLE DOORS	No Charge
Add ACPOS-18	Pull-out Equipment Tray	+1,003



OS2DD-1 |

OS2LD-B	CENTER BOX/LARGE BOX DRAWER	+742
---------	------------------------------------	------



OS2LD-1 |

OS2LO-B	CENTER BOX/OPEN SHELVES	No Charge
---------	--------------------------------	-----------



OS2LO-1 |



CONFERENCE HEIGHT WITH PLINTH BASE

MODEL NUMBER: ACCD-10830

STEP 1: CASE STYLE

MUST SPECIFY

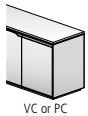

VC or PC



BVC or BPC

STANDARD CASE		STARTING PRICE
VC	24.5"D Veneer Case	10,322
PC	24.5"D Painted Case	9,596

BEVELED CASE		STARTING PRICE
BVC	24.5"D Veneer Case	14,037
BPC	24.5"D Painted Case	13,034

STEP 2: TOP MATERIAL AND EDGE PROFILE

MUST SPECIFY



Square Edge



2" Square Edge



Chamfer Edge

TOP WITH SQUARE EDGE		VC / PC	BVC / BPC
P	3/4" Laminate with Hardwood Edge	+1,884	+2,564
PE	3/4" Laminate with ABS Edge	+1,722	+2,372
XE	3/4" Fenix with ABS Edge	+2,994	+4,086
V	3/4" Veneer with Hardwood Edge	+2,514	+3,420
X	3/4" Fenix with Hardwood Edge	+3,482	+4,736
GG	3/8" Gloss Glass	+4,520	+6,146
2V	2" Veneer with Hardwood Edge	+5,289	+6,808
SG	3/8" Satin Glass	+5,837	+7,192
S	2cm Stone	+7,374	+10,029

TOP WITH CHAMFER EDGE		VC / PC	BVC / BPC
CV	3/4" Veneer	+3,482	+4,736
CS	2cm Stone	+8,310	+11,302

STEP 3: DOOR/DRAWER STYLE

Defaults to match case, if none selected

PAD	Painted	No Charge
HD	Horizontal Veneer	No Charge
VD	Vertical Veneer	No Charge
PWD	Plank Veneer	+302

STEP 4: PULL STYLE

MUST SPECIFY



Integrated Pull



Metal Tab Pull



Handle Pull

INTEGRATED PULL		
MIP	Powder Coat	No Charge
CAIP	Clear Anodized	No Charge
PCIP-108	Polished Chrome	+439

OPTIONS	CODE	PRICE
Wood Accent	Add WIP-108	+342

METAL TAB PULL		
MP	Powder Coat	No Charge
CAMP	Clear Anodized	No Charge
PCMP-108	Polished Chrome	+826

HANDLE PULL		
HP-108	Powder Coat	+841
CAHP-108	Clear Anodized	+841
PCHP-108	Polished Chrome	+1,073

STEP 5: HARDWARE OPTIONS

LOCKS		
L	Door Locks	+270

RAISED BACKSTOP		
RB-108	Powder Coat	+545
CARB-108	Clear Anodized	+545
APSRB-108	Polished Stainless	+1,973

REVEAL		
MR-10824	Powder Coat	+957
CAMR-10824	Clear Anodized	+957
APSMR-10824	Polished Stainless	+1,353

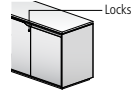

Locks

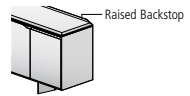

Raised Backstop

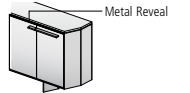

Metal Reveal

STEP 6: CASE CONFIGURATION

Defaults to Double Doors with Adjustable Height Shelves in all locations, if none selected

[] Select configuration and desired components for each cabinet location.

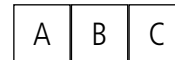

DD-[]	DOUBLE DOOR (DEFAULT)	No Charge
Add ACPOS-24	Pull-out Equipment Tray	+1,003
Add R2	Fixed Equipment Rack (12RU)	+836
Add R1	Sliding Equipment Rack (12RU)	+2,746

PULL OUT SINGLE DOOR		
SD-[]-TF	Pull Out Waste/Recycling	+1,248
SD-[]-OMF	Drawer Refrigerator	+10,370

SEAMED PULL-OUT SINGLE DOOR		
SDF-[]-TF	Pull Out Waste/Recycling	+1,248
SDF-[]-OMF	Drawer Refrigerator	+10,370

D2DD-[]	BOX DRAWER/DOUBLE DOORS	+1,229
Add CD	Charging Drawer	+2,343
Add ACPOS-24	Pull-out Equipment Tray	+1,003

D2LD-[]	BOX DRAWER/LARGE BOX DRAWER	+1,968
Add CD	Charging Drawer	+2,343

OS2DD-[]	CENTER BOX/DOUBLE DOORS	No Charge
Add ACPOS-24	Pull-out Equipment Tray	+1,003

OS2LD-[]	CENTER BOX/LARGE BOX DRAWER	+742
-----------	------------------------------------	------

OS2LO-[]	CENTER BOX/OPEN SHELVES	No Charge
-----------	--------------------------------	-----------



DD-1 |



SD-1 |



SDF-1 |



D2DD-1 |



D2LD-1 |



OS2DD-1 |



OS2LD-1 |



OS2LO-1 |

STEP 7: ACCESSORIES

See page 36 for additional accessories

BOX DRAWER ORGANIZER		
ACBO-24-W	24.5"D Walnut Organizer	+915
ACBO-24-B	24.5"D Birch Organizer	+512
ACBO-24-A	24.5"D Ash Organizer	+915



BOX DRAWER ORGANIZER

LARGE BOX DRAWER PEG BOARD SYSTEM		
ACFO-24-W	24.5"D Walnut Peg Board System	+1,398
ACFO-24-B	24.5"D Birch Peg Board System	+742
ACFO-24-A	24.5"D Ash Peg Board System	+1,165

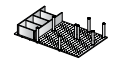

PEG BOARD SYSTEM



BUFFET HEIGHT WITH METAL BASE

MODEL NUMBER: ACCC-7234

STEP 1: CASE STYLE

MUST SPECIFY

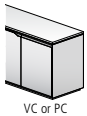

VC or PC



BVC or BPC

STANDARD CASE		STARTING PRICE
VC	18" D Veneer Case	8,676
PC	18" D Painted Case	8,171

BEVELED CASE		STARTING PRICE
BVC	18" D Veneer Case	11,797
BPC	18" D Painted Case	10,955

STEP 2: TOP MATERIAL AND EDGE PROFILE

MUST SPECIFY



Square Edge



2" Square Edge



Chamfer Edge

TOP WITH SQUARE EDGE		VC / PC	BVC / BPC
P	3/4" Laminate with Hardwood Edge	+1,502	+2,045
PE	3/4" Laminate with ABS Edge	+1,731	+2,178
XE	3/4" Fenix with ABS Edge	+2,002	+2,541
V	3/4" Veneer with Hardwood Edge	+2,180	+2,966
X	3/4" Veneer with Hardwood Edge	+2,886	+3,924
GG	3/8" Gloss Glass	+3,687	+5,016
2V	2" Veneer with Hardwood Edge	+4,267	+5,431
SG	3/8" Satin Glass	+4,597	+5,920
S	2cm Stone	+5,703	+7,758

TOP WITH CHAMFER EDGE		VC / PC	BVC / BPC
CV	3/4" Veneer	+2,886	+3,924
CS	2cm Stone	+6,383	+8,682

STEP 3: DOOR/DRAWER STYLE

Defaults to match case, if none selected

PAD	Painted	No Charge
HD	Horizontal Veneer	No Charge
VD	Vertical Veneer	No Charge
PWD	Plank Veneer	+302

STEP 4: PULL STYLE

MUST SPECIFY



Integrated Pull



Metal Tab Pull



Handle Pull

INTEGRATED PULL		
MIP	Powder Coat	No Charge
CAIP	Clear Anodized	No Charge
PCIP-72	Polished Chrome	+293

OPTIONS	CODE	PRICE
Wood Accent	Add WIP-72	+228

METAL TAB PULL		
MP	Powder Coat	No Charge
CAMP	Clear Anodized	No Charge
PCMP-72	Polished Chrome	+550

HANDLE PULL		
HP-72	Powder Coat	+560
CAHP-72	Clear Anodized	+560
PCHP-72	Polished Chrome	+716

STEP 5: HARDWARE OPTIONS

LOCKS		
L	Door Locks	+270

METAL BASE OPTIONS Defaults to Powder Coat, if none selected		
PCMB	Polished Chrome	+405

RAISED BACKSTOP		
RB-72	Powder Coat	+482
CARB-72	Clear Anodized	+482
APSRB-72	Polished Stainless	+1,720

REVEAL		
MR-7218	Powder Coat	+892
CAMR-7218	Clear Anodized	+892
APSMR-7218	Polished Stainless	+1,184

STEP 6: CASE CONFIGURATION

Defaults to Double Doors with Adjustable Height Shelves in all locations, if none selected

[] Select configuration and desired components for each cabinet location.

A	B
---	---

DD-[]	DOUBLE DOOR (DEFAULT)	No Charge
Add ACPOS-18	Pull-out Equipment Tray	+1,003

D2DD-[]	BOX DRAWER/DOUBLE DOORS	+1,229
Add CD	Charging Drawer	+2,343
Add ACPOS-18	Pull-out Equipment Tray	+1,003

D2LD-[]	BOX DRAWER/LARGE BOX DRAWER	+1,968
Add CD	Charging Drawer	+2,343

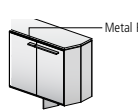
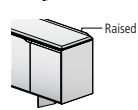
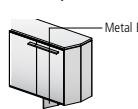
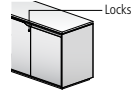



BUFFET HEIGHT WITH METAL BASE

MODEL NUMBER: ACCD-7234

STEP 1: CASE STYLE

MUST SPECIFY



VC or PC



BVC or BPC

STANDARD CASE		STARTING PRICE
VC	24.5" D Veneer Case	9,532
PC	24.5" D Painted Case	8,978

BEVELED CASE		STARTING PRICE
BVC	24.5" D Veneer Case	12,963
BPC	24.5" D Painted Case	12,037

STEP 2: TOP MATERIAL AND EDGE PROFILE

MUST SPECIFY



Square Edge



2" Square Edge



Chamfer Edge

TOP WITH SQUARE EDGE		VC / PC	BVC / BPC
P	3/4" Laminate with Hardwood Edge	+1,584	+2,155
PE	3/4" Laminate with ABS Edge	+1,675	+2,328
XE	3/4" Fenix with ABS Edge	+2,789	+3,806
V	3/4" Veneer with Hardwood Edge	+2,111	+3,045
X	3/4" Veneer with Hardwood Edge	+2,927	+3,981
GG	3/8" Gloss Glass	+3,799	+5,168
2V	2" Veneer with Hardwood Edge	+4,446	+5,759
SG	3/8" Satin Glass	+4,906	+6,045
S	2cm Stone	+6,053	+8,231

TOP WITH CHAMFER EDGE		VC / PC	BVC / BPC
CV	3/4" Veneer	+2,927	+4,100
CS	2cm Stone	+6,832	+9,291

STEP 3: DOOR/DRAWER STYLE

Defaults to match case, if none selected

PAD	Painted	No Charge
HD	Horizontal Veneer	No Charge
VD	Vertical Veneer	No Charge
PWD	Plank Veneer	+302

STEP 4: PULL STYLE

MUST SPECIFY



Integrated Pull



Metal Tab Pull



Handle Pull

INTEGRATED PULL		
MIP	Powder Coat	No Charge
CAIP	Clear Anodized	No Charge
PCIP-72	Polished Chrome	+293

OPTIONS	CODE	PRICE
Wood Accent	Add WIP-72	+228

METAL TAB PULL		
MP	Powder Coat	No Charge
CAMP	Clear Anodized	No Charge
PCMP-72	Polished Chrome	+550

HANDLE PULL		
HP-72	Powder Coat	+560
CAHP-72	Clear Anodized	+560
PCHP-72	Polished Chrome	+716

STEP 5: HARDWARE OPTIONS

LOCKS		
L	Door Locks	+270

METAL BASE OPTIONS Defaults to Powder Coat, if none selected		
PCMB	Polished Chrome	+405

RAISED BACKSTOP		
RB-72	Powder Coat	+482
CARB-72	Clear Anodized	+482
APSRB-72	Polished Stainless	+1,720

REVEAL		
MR-7224	Powder Coat	+909
CAMR-7224	Clear Anodized	+909
APSMR-7224	Polished Stainless	+1,226

STEP 6: CASE CONFIGURATION

Defaults to Double Doors with Adjustable Height Shelves in all locations, if none selected

[] Select configuration and desired components for each cabinet location.

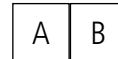

DD-[]	DOUBLE DOOR (DEFAULT)	No Charge
Add ACPOS-24	Pull-out Equipment Tray	+1,003
Add R2	Fixed Equipment Rack (12RU)	+836
Add R1	Sliding Equipment Rack (12RU)	+2,746

PULL OUT SINGLE DOOR		
SD-[]-TF	Pull Out Waste/Recycling	+1,248
SD-[]-OMF	Drawer Refrigerator	+10,370

SEAMED PULL-OUT SINGLE DOOR		
SDF-[]-TF	Pull Out Waste/Recycling	+1,248
SDF-[]-OMF	Drawer Refrigerator	+10,370

D2DD-[]	BOX DRAWER/DOUBLE DOORS	+1,229
Add CD	Charging Drawer	+2,343
Add ACPOS-24	Pull-out Equipment Tray	+1,003

D2LD-[]	BOX DRAWER/LARGE BOX DRAWER	+1,968
Add CD	Charging Drawer	+2,343

STEP 7: ACCESSORIES

See page 36 for additional accessories

BOX DRAWER ORGANIZER		
ACBO-24-W	24.5" D Walnut Organizer	+915
ACBO-24-B	24.5" D Birch Organizer	+512
ACBO-24-A	24.5" D Ash Organizer	+915

LARGE BOX DRAWER PEG BOARD SYSTEM		
ACFO-24-W	24.5" D Walnut Peg Board System	+1,398
ACFO-24-B	24.5" D Birch Peg Board System	+742
ACFO-24-A	24.5" D Ash Peg Board System	+1,165

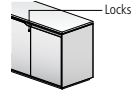

Locks

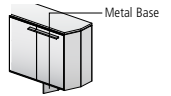

Metal Base

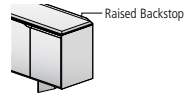

Raised Backstop

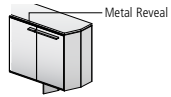

Metal Reveal



DD-1



SD-1



SDF-1



D2DD-1



D2LD-1



BOX DRAWER ORGANIZER



PEG BOARD SYSTEM



BUFFET HEIGHT WITH METAL BASE

MODEL NUMBER: ACCC-10834

STEP 1: CASE STYLE

MUST SPECIFY

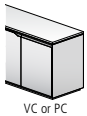

STANDARD CASE		STARTING PRICE
VC	18" D Veneer Case	10,324
PC	18" D Painted Case	9,725

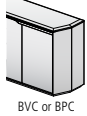

BEVELED CASE		STARTING PRICE
BVC	18" D Veneer Case	14,039
BPC	18" D Painted Case	13,036

STEP 2: TOP MATERIAL AND EDGE PROFILE

MUST SPECIFY



TOP WITH SQUARE EDGE		VC / PC	BVC / BPC
P	3/4" Laminate with Hardwood Edge	+1,788	+2,433
PE	3/4" Laminate with ABS Edge	+1,591	+2,226
XE	3/4" Fenix with ABS Edge	+1,877	+2,649
V	3/4" Veneer with Hardwood Edge	+2,594	+3,530
X	3/4" Veneer with Hardwood Edge	+3,434	+4,670
GG	3/8" Gloss Glass	+4,387	+5,968
2V	2" Veneer with Hardwood Edge	+5,076	+6,463
SG	3/8" Satin Glass	+5,471	+7,045
S	2cm Stone	+6,938	+9,437



TOP WITH CHAMFER EDGE		VC / PC	BVC / BPC
CV	3/4" Veneer	+3,434	+4,670
CS	2cm Stone	+7,756	+10,548

STEP 3: DOOR/DRAWER STYLE

Defaults to match case, if none selected

PAD	Painted	No Charge
HD	Horizontal Veneer	No Charge
VD	Vertical Veneer	No Charge
PWD	Plank Veneer	+302

STEP 4: PULL STYLE

MUST SPECIFY



INTEGRATED PULL		
MIP	Powder Coat	No Charge
CAIP	Clear Anodized	No Charge
PCIP-108	Polished Chrome	+439



OPTIONS	CODE	PRICE
Wood Accent	Add WIP-108	+342



METAL TAB PULL		
MP	Powder Coat	No Charge
CAMP	Clear Anodized	No Charge
PCMP-108	Polished Chrome	+826

HANDLE PULL		
HP-108	Powder Coat	+841
CAHP-108	Clear Anodized	+841
PCHP-108	Polished Chrome	+1,073

STEP 5: HARDWARE OPTIONS

LOCKS		
L	Door Locks	+270

METAL BASE OPTIONS Defaults to Powder Coat, if none selected		
PCMB	Polished Chrome	+405

RAISED BACKSTOP		
RB-108	Powder Coat	+545
CARB-108	Clear Anodized	+545
APSRB-108	Polished Stainless	+1,973

REVEAL		
MR-10818	Powder Coat	+941
CAMR-10818	Clear Anodized	+941
APSMR-10818	Polished Stainless	+1,311

STEP 6: CASE CONFIGURATION

Defaults to Double Doors with Adjustable Height Shelves in all locations, if none selected

[] Select configuration and desired components for each cabinet location.

A	B	C
---	---	---

DD-[]	DOUBLE DOOR (DEFAULT)	No Charge
Add ACPOS-18	Pull-out Equipment Tray	+1,003

D2DD-[]	BOX DRAWER/DOUBLE DOORS	+1,229
Add CD	Charging Drawer	+2,343
Add ACPOS-18	Pull-out Equipment Tray	+1,003

D2LD-[]	BOX DRAWER/LARGE BOX DRAWER	+1,968
Add CD	Charging Drawer	+2,343

OS2DD-B	CENTER BOX/DOUBLE DOORS	No Charge
Add ACPOS-18	Pull-out Equipment Tray	+1,003

OS2LD-B	CENTER BOX/LARGE BOX DRAWER	+742
---------	------------------------------------	------

OS2LO-B	CENTER BOX/OPEN SHELVES	No Charge
---------	--------------------------------	-----------

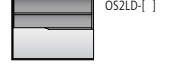
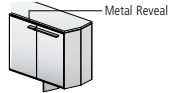
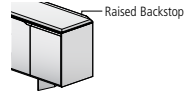
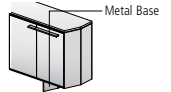
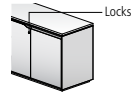



BUFFET HEIGHT WITH METAL BASE

MODEL NUMBER: ACCD-10834

STEP 1: CASE STYLE

MUST SPECIFY

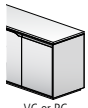

VC or PC



BVC or BPC

STANDARD CASE		STARTING PRICE
VC	24.5" D Veneer Case	11,344
PC	24.5" D Painted Case	10,683

BEVELED CASE		STARTING PRICE
BVC	24.5" D Veneer Case	15,426
BPC	24.5" D Painted Case	14,325

STEP 2: TOP MATERIAL AND EDGE PROFILE

MUST SPECIFY



Square Edge



2" Square Edge



Chamfer Edge

TOP WITH SQUARE EDGE		VC / PC	BVC / BPC
P	3/4" Laminate with Hardwood Edge	+1,884	+2,564
PE	3/4" Laminate with ABS Edge	+1,722	+2,372
XE	3/4" Fenix with ABS Edge	+2,994	+4,086
V	3/4" Veneer with Hardwood Edge	+2,514	+3,420
X	3/4" Fenix with Hardwood Edge	+3,482	+4,736
GG	3/8" Gloss Glass	+4,520	+6,146
2V	2" Veneer with Hardwood Edge	+5,289	+6,808
SG	3/8" Satin Glass	+5,837	+7,192
S	2cm Stone	+7,374	+10,029

TOP WITH CHAMFER EDGE		VC / PC	BVC / BPC
CV	3/4" Veneer	+3,482	+4,736
CS	2cm Stone	+8,310	+11,302

STEP 3: DOOR/DRAWER STYLE

Defaults to match case, if none selected

PAD	Painted	No Charge
HD	Horizontal Veneer	No Charge
VD	Vertical Veneer	No Charge
PWD	Plank Veneer	+302

STEP 4: PULL STYLE

MUST SPECIFY



Integrated Pull



Metal Tab Pull



Handle Pull

INTEGRATED PULL		
MIP	Powder Coat	No Charge
CAIP	Clear Anodized	No Charge
PCIP-108	Polished Chrome	+439

OPTIONS	CODE	PRICE
Wood Accent	Add WIP-108	+342

METAL TAB PULL		
MP	Powder Coat	No Charge
CAMP	Clear Anodized	No Charge
PCMP-108	Polished Chrome	+826

HANDLE PULL		
HP-108	Powder Coat	+841
CAHP-108	Clear Anodized	+841
PCHP-108	Polished Chrome	+1,073

STEP 5: HARDWARE OPTIONS

LOCKS		
L	Door Locks	+270

METAL BASE OPTIONS Defaults to Powder Coat, if none selected		
PCMB	Polished Chrome	+405

RAISED BACKSTOP		
RB-108	Powder Coat	+545
CARB-108	Clear Anodized	+545
APSRB-108	Polished Stainless	+1,973

REVEAL		
MR-10824	Powder Coat	+957
CAMR-10824	Clear Anodized	+957
APSMR-10824	Polished Stainless	+1,353

STEP 6: CASE CONFIGURATION

Defaults to Double Doors with Adjustable Height Shelves in all locations, if none selected

[] Select configuration and desired components for each cabinet location.

A	B	C
---	---	---

DD-[]	DOUBLE DOOR (DEFAULT)	No Charge
Add ACPOS-24	Pull-out Equipment Tray	+1,003
Add R2	Fixed Equipment Rack (12RU)	+836
Add R1	Sliding Equipment Rack (12RU)	+2,746

PULL OUT SINGLE DOOR		
SD-[]-TF	Pull Out Waste/Recycling	+1,248
SD-[]-OMF	Drawer Refrigerator	+10,370

SEAMED PULL-OUT SINGLE DOOR		
SDF-[]-TF	Pull Out Waste/Recycling	+1,248
SDF-[]-OMF	Drawer Refrigerator	+10,370

D2DD-[]	BOX DRAWER/DOUBLE DOORS	+1,229
Add CD	Charging Drawer	+2,343
Add ACPOS-24	Pull-out Equipment Tray	+1,003

D2LD-[]	BOX DRAWER/LARGE BOX DRAWER	+1,968
Add CD	Charging Drawer	+2,343

OS2DD-[]	CENTER BOX/DOUBLE DOORS	No Charge
Add ACPOS-24	Pull-out Equipment Tray	+1,003

OS2LD-[]	CENTER BOX/LARGE BOX DRAWER	+742
-----------	------------------------------------	------

OS2LO-[]	CENTER BOX/OPEN SHELVES	No Charge
-----------	--------------------------------	-----------

STEP 7: ACCESSORIES

See page 36 for additional accessories

BOX DRAWER ORGANIZER		
ACBO-24-W	24.5" D Walnut Organizer	+915
ACBO-24-B	24.5" D Birch Organizer	+512
ACBO-24-A	24.5" D Ash Organizer	+915

LARGE BOX DRAWER PEG BOARD SYSTEM		
ACFO-24-W	24.5" D Walnut Peg Board System	+1,398
ACFO-24-B	24.5" D Birch Peg Board System	+742
ACFO-24-A	24.5" D Ash Peg Board System	+1,165

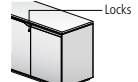

Locks

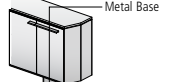

Metal Base

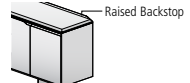

Raised Backstop

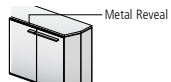

Metal Reveal

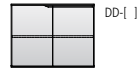

DD-[]



SD-[]



SDF-[]



D2DD-[]



D2LD-[]



OS2DD-[]



OS2LD-[]



OS2LO-[]



BOX DRAWER ORGANIZER



PEG BOARD SYSTEM



ACCESSORIES

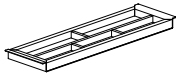

PENCIL TRAY

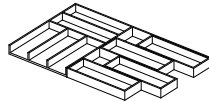

DRAWER ORGANIZER

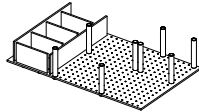

PEG BOARD SYSTEM

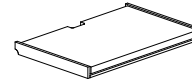

PULL-OUT EQUIPMENT TRAY

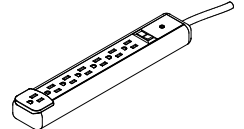

PLUG STRIP

DRAWER LINER INSERT

MODEL #	DESCRIPTION	PRICE
LDI-18	18" depth - Knoll Felt or Brisa® UltraFabrics® Drawer Liner Inserts	51
LDI-24	24.5" depth - Knoll Felt or Brisa® UltraFabrics® Drawer Liner Inserts	58

PENCIL TRAY

MODEL #	W x D x H	DESCRIPTION	PRICE
ACPT-18	13 x 4.25 x 1	Pencil Tray for Box Drawer -18" depth. Fits 18" depth Double Doors.	267
ACPT-24	13 x 4.25 x 1	Pencil Tray for Box Drawer -24.5" depth. Fits 24.5" depth Double Doors.	267

DRAWER INSERT

MODEL #	DESCRIPTION	PRICE
ACBO-24-W	Walnut Box Drawer Organizer. Fits 24.5" depth Box Drawers. Complete set of Drawer Dividers.	917
ACBO-24-B	Birch Box Drawer Organizer. Fits 24.5" depth Box Drawers. Complete set of Drawer Dividers.	513
ACBO-24-A	Ash Box Drawer Organizer. Fits 24.5" depth Box Drawers. Complete set of Drawer Dividers.	917
ACFO-24-W	Walnut Large Box Drawer Peg Board System. Fits 24.5" depth Large Box Drawers. Complete Peg Board System with Dividers.	1,400
ACFO-24-B	Birch Large Box Drawer Peg Board System. Fits 24.5" depth Large Box Drawers. Complete Peg Board System with Dividers.	743
ACFO-24-A	Ash Large Box Drawer Peg Board System. Fits 24.5" depth Large Box Drawers. Complete Peg Board System with Dividers.	1,166

PULL-OUT EQUIPMENT TRAY RETROFIT KIT

MODEL #	DESCRIPTION	PRICE
ACPOS-18-V	Veneer, Pull-out Equipment Tray - 18" depth. Fits 18" depth double doors.	1,003
ACPOS-24-V	Veneer, Pull-out Equipment Tray - 24.5" depth. Fits 24.5" depth double doors.	1,003
ACPOS-18-P	Paint, Pull-out Equipment Tray - 18" depth. Fits 18" depth double doors.	1,003
ACPOS-24-P	Paint, Pull-out Equipment Tray - 24.5" depth. Fits 24.5" depth double doors.	1,003

PLUG STRIP

MODEL #	W x D x H	DESCRIPTION	PRICE
MOA-10	2.05 x 11.69 x 1.32	Black Power Plug Strip.	190

GENERAL INFORMATION

- 15 amps, includes (7) outlets, surge protection and 10' electrical cord



Appendix



GENERAL INFORMATION

This price book supercedes all previous versions.

Before placing your order, confirm you have all required information necessary. Lead times for orders begin after all required information is included and correct.

Delivery Information

We know lead times are important and sticking to them even more so. We work to maintain a 6-8 week lead time on all standard products in this book from receipt of a clean order. All orders are acknowledged with an approximate shipping date and will be invoiced with the price in effect at the date the purchase order is received. For current lead times, please review www.nucraft.com/resources/lead-times.

Shipping charges are prepaid (within the continental U.S.). Therefore, pricing is a delivered price based on normal ground transportation. If you have special instructions, need to ship by air, or are shipping to Alaska or Hawaii, contact Nucraft Customer Service. Nucraft can also help arrange to have products blanket wrapped for an additional charge. Contact the Nucraft Customer Service team or specify it on your purchase order.

Minimum Freight Charge: Any order below \$2,900 net will be assessed a \$475 net minimum freight charge (one per order).

Orders are subject to acquiring the materials required for manufacturing. Fulfillment can be affected by strikes, fires, embargoes and acts of government. These elements are beyond our control.

Nucraft offers a variety of services to accommodate a wide range of delivery requirements. Availability of these services is dependent on a number of factors and may not be offered with all shipments. Examples of delivery services that have additional fees include:

- Specific date
- Specific time of day, morning or afternoon
- Delivery to a warehouse before delivery to its final destination (unless product is picked up at the warehouse)

Contact the Nucraft Customer Service team for availability and pricing on these services.

Freight Terms

Shipping charges for Nucraft products are prepaid for standard delivery in the continental United States. Standard delivery is defined as follows: Product is delivered on a 53' trailer being pulled by a long-haul tractor (total length of 85'). Facility will receive delivery Monday through Friday between the hours of 8:00 AM and 4:00 PM. Facility has docks with levelers and a fork truck for unloading. Product will be loaded on load bars two levels high. Receiving facility is responsible to have personnel on hand to unload the truck upon arrival, drivers do not unload. Delivery sites or times that do not meet these criteria may be accommodated, but will incur a charge to cover additional shipping costs. Please **notify Nucraft a minimum of two weeks prior to shipment** to arrange special services and determine additional charges.

Storage

Nucraft has no storage facilities for finished product. If a customer cannot accept an order when it is ready for shipment, the customer must designate an alternative shipping address. If no address is provided, Nucraft may, at its discretion, transfer the product to storage. If product is transferred to an off-site storage facility, the customer may be charged for transportation to the facility and for any associated storage fees. Nucraft considers transfer of the product to a storage facility the equivalent of shipment, including invoicing and payment. Customers assume the risk of damage or loss during storage.

Transportation Times and Delays

Third party carriers that Nucraft contracts with will make reasonable efforts to accommodate requested delivery times and dates. Scheduled delivery appointments may, however, be delayed for a variety of reasons, including inclement weather, traffic, transportation equipment problems, and delays encountered at other delivery locations along the delivery route. Nucraft does not recommend scheduling activities that depend on the delivery appointment (for example, scheduling furniture installers to install furniture the day of the delivery appointment). Nucraft shall not be liable for any costs incurred as a result of a missed delivery appointment.

Shipment Damage Claims

Legal title to merchandise passes to the buyer upon acceptance by the carrier. Inspect all cartons upon delivery. Details of visible damage should be noted on the delivery receipt. Do not destroy packaging, transport to site, or install product if damage is found upon inspection. Inspection of products should be completed upon delivery to the receiver. If visible damage is apparent, a claim should be filed immediately with Nucraft Customer Service. If visible damage is not apparent, sign the delivery receipt "No visible damage." This will allow recourse for a concealed damage claim. Concealed damage claims must be filed within 15 days of receipt, **prior to transporting or installing any product.**

Do not destroy packing materials until shipment has been inspected. If damage is found, proceed to file a claim with Nucraft Customer Service.

Failure to make any claims against Nucraft within 15 days shall constitute acceptance of the merchandise and a waiver of any defects, errors or shortages discovered upon inspection.

Cancellations

Cancellations must be reviewed by our Customer Service team. Because we build your products to order, orders cannot be cancelled once processing has begun. Processing includes but is not limited to development of shop drawings and other engineering drawings. If cancellation is approved, a processing fee of 20-100% will be assessed based on the status of the order.

Change Order Policy

Nucraft will make every attempt to honor any reasonable change request to product provided that the request is received prior to start of production. Change orders will be accepted only if the request is made in writing and received in time to make the change. Nucraft reserves the right to increase our acknowledged price and ship date if necessary to make the requested changes. Please submit any change order request to our Customer Service team. Nucraft will assess charges to the customer as stipulated in the following:

- Standard Orders: Change orders received prior to production will be charged \$400 net to cover administrative costs.
- Special Orders: Change orders received prior to production will be charged \$400 net to cover administrative costs. There may be additional costs associated with engineering labor required for the change order.
- Change orders received after production must be evaluated by Nucraft. If approved, the charge will be \$400 net plus any restocking charges accumulated. There may be additional costs associated with engineering and/or manufacturing labor, as well as material costs, required for the change order.



GENERAL INFORMATION

Repair Authorization

Prior written approval is required for repairs of merchandise charged to Nucraft. Failure to do so will result in customer funded repairs.

Payment Terms

Deposits are required at the time of order due to the custom nature of our products. See information regarding Cancellations above.

Credit terms are available to qualified customers. Please contact AR@Nucraft.com to start the application process. Note that the credit application process requires a valid sales tax exemption or resale tax certificate, Form W-9, and three current trade references.

Credit Card Payments are accepted via web portal. Please contact AR@Nucraft.com for payment instructions. Note that a 2% convenience fee will be added for using this payment method and no early pay discounts are allowed on credit card payments.

Warranty

Nucraft Furniture is warranted to be free from defects in materials and workmanship for a period of ten years of single shift use. Limitations include:

- Mechanical Devices such as latches, casters, and other moving components are warranted for five years of the date of original delivery.
- Height adjustable components are warranted for two years of the date of original delivery.
- The following are warranted for one year of the date of original delivery:
 - Textiles
 - Electrical Components
 - Refrigeration Units
 - Custom Products not described in Nucraft's Catalogue

This warranty is applicable only if furniture is properly installed and maintained in an office environment. This warranty extends only to products manufactured and sold in North America and only to original purchasers acquiring new Nucraft product through authorized dealers or approved sellers.

During this warranty period, Nucraft's sole obligation is to repair or replace, at Nucraft's discretion, products which prove to be defective during the warranty period.

This warranty does not cover:

- Damage caused by a carrier.
- Damage from user modification, misuse, abuse, accident, or negligence.
- Customer's Own Material (COM) specified by the customer that is not a standard product offering.
- Color, grain, or texture of wood and other covering material.

Nucraft extends no other warranties, expressed or implied, including warranty of merchantability or fitness for a particular purpose. Nucraft shall not be liable for loss of time, inconvenience, commercial loss, incidental or consequential damages.

Environmental Statement

Nucraft is committed to supporting responsible environmental policies and practices in all that we do. We strive for sustainability, weighing our business decisions against the costs to the ecological, social and economic systems they affect.

Our products are manufactured to meet the credit requirements of the U.S. Green Building Council's LEED rating systems in one or more of the following categories:

- Recycled Content
- Certified Wood
- Low-Emitting Materials

Computer Aided Planning

Nucraft products and pricing are available via CET and 2020 Cap, an AutoCAD®-based space planning tool.

2020 Cap is an integrated software system developed specifically for interior designers and facility planners to enhance workplace performance. This modern suite of applications works together seamlessly, in concert. Navigate catalogs, select products, design in plan view and 3D, assign options, create worksheets and build a project where you want, when you want. Take your pick. It's dynamic and interactive. Design projects are a work in progress. And now you can perform any of the many discrete tasks that go into a project any time, any place.

For additional information, you may contact 2020 Cap direct at 800-227-0038.

Product symbols (Revit, 2D and 3D) are available on the Nucraft website at www.nucraft.com/resources/product-symbols.

iSpec®

Nucraft offers a free online product configuration and specification service that saves you time and allows you to be creative while leaving the nuts and bolts to someone else. No specific software is required, nor is there any learning curve. This service applies to all Nucraft products. For additional information, call 1-877-NUCRAFT and ask for the iSpec Team or log on to www.nucraft.com/resources/ispec.



FINISH INFORMATION

Surface Materials Palette

We crafted our materials palette using the same demanding standards that distinguish our furniture. Thoughtful design and attention to every detail elevate your possibilities.

Anchored by Nucraft veneers, unrivaled for clarity, quality, and depth of finish, our collection of surface materials comprises a sophisticated set of balanced elements that supports your design vision.

Some elements have their roots in Nucraft's rich heritage. Others are new materials and reflect current trends and taste. Together, they ensure that you're ready for today and positioned well for the future. Beautifully.

Custom Finishes

Nucraft specializes in expert custom finish matching. For a nominal upcharge we can provide custom finishes, and we are frequently asked to match the finishes of other furniture manufacturers. For finishes that appear unusual to match or for customers directly requesting a sample, a finish sample will be sent for approval prior to entering the order.

Custom finishes requiring colored varnishes to create a painted look can only be applied to Maple veneer and require one extra week in addition to the standard lead time. Nucraft's standard black finish (G82) can be applied to all Nucraft standard veneers. Walnut is the standard black veneer. Other species must be specified when ordering.

Clear coat on a special veneer requires an approved sample.

Custom finishes carry a 10% upcharge per item, per finish, capped at \$2,100 List.

Custom finish upcharges are not applied to any item that is not wood. Example: casters, ganging connectors, power options..

Treatments

Note: Default veneer sheen will vary per finish and product. Default finish is bolded on pages vi-vii. If no direction is provided on incoming orders, default sheen will be selected. In addition, default veneer cut is noted in the price list. If no direction is provided on incoming orders, default cut will be selected.

Gloss: Gloss is a durable finish that tends to nicely mask normal wear and leaves wood grain visible to the eye. It achieves a medium gloss open pore appearance (40 – 50 sheen range). Finish numbers preceded by the letter "G" indicate a Gloss finish.

Matte: Like Gloss, Matte is durable, tends to nicely mask normal wear and leaves wood grain visible to the eye. It achieves a low luster, open pore appearance (10 – 20 sheen range). Finish numbers preceded by the letter "M" indicate a Matte finish.

Since each veneer type responds differently to both types of treatment, all will have a distinctive look and feel when finished. For example, a Walnut veneer with a Gloss treatment will remain much more textured than a Cherry veneer with the same treatment.

About the Wood

All Nucraft veneers are carefully selected for uniformity of color and grain. Still, wood is a natural substance and minor variations may occur due to its own uniqueness. Because of this, the furniture you receive may not be an exact match to our samples.

Nucraft takes great pride in our finish color consistency. However, wood is a natural product that will have color variation within a single piece of furniture, as well as from one piece to the next. Other factors also affect color over time, such as exposure to light (both intensity and duration). For example, lighter finishes cause more variation in colors over time.

In cases where a returning customer wants a precise match with existing furniture, we recommend sending a sample of the existing furniture finish. Please contact Nucraft Customer Service to determine an appropriate sample. This will ensure a finish match between old and new orders. This type of order is considered a control sample. There will be a 10% upcharge on an order of this type. Due to natural aging of veneers, natural finishes may vary.

Care and Maintenance of Wood Finishes

Our finish material is a crystal clear, urethane acrylic blend. This type of finish may be repaired in the field by a qualified refinisher.

Nucraft recommends using a damp cloth to clean your fine wood furniture. Always wipe with the grain of the wood. Should your wood furniture require a more thorough cleaning, we recommend using a mild cleaner such as Joy dish soap or Murphy's oil soap, thoroughly diluted in water (one part soap to thirty parts water). Water will not damage Nucraft's finish, but it may leave surface spots when it dries. To avoid this, dry the surface with a soft cloth after it is cleaned. Marks that cannot be removed with the cleaning methods above may be able to be removed using naphtha, a mild degreasing solvent.

Caution: while the use of polishes that contain wax, petroleum solvents or silicones may immediately enhance the "shine" of a product, it may also eventually remove the fine original finish applied in our factory. Silicone on the surface of wood may also make it very difficult to respray or refinish.

All Nucraft furniture is inspected and polished before it leaves our factory. In some instances, the packing materials may imprint on the factory polish. Cleaning and polishing the furniture once it is unpacked will normally restore the furniture to its original beauty.

In some cases, the rubber support feet used on the bottom of common office equipment (teleconferencing phones, laptops, microphones, copiers, etc.) can create unsightly marks in the surface of wood tops, due to oxidation of the lacquer finish. We suggest these machines be placed on a protective type of padding, such as felt.

Wood will fade as a result of exposure to UV light. This is particularly prevalent with light finishes. If color changes due to fading are a concern for your application, the impact can be minimized by selecting medium to dark stains for your wood surfaces. Our top coat includes a UV inhibitor which makes the finishes less prone to fading.



FINISH INFORMATION

Laminates

Selected Formica®, Nevamar®, and Wilsonart® laminates are available on Training Tables, Conference Tables, Conference Room Furniture and select Occasional Tables. For standard laminate and wood pricing, refer to individual item pricing columns.

Non-Standard Laminates and Linoleums

To order a color other than those on our list (see pages vi-vii), refer to Nevamar or Formica standard grade, matte texture laminate offerings and Forbo Furniture Linoleums (excluding manufacturers' non-standard matte offering).

Nucraft can support other laminate and linoleum options beyond what can be found as standard options on pages vi-viii. For pricing, please send a request to quotes@nucraft.com.

Care and Maintenance of Laminate and Novawrap

Laminate and Novawrap surfaces may be cleaned with a damp cloth and ordinary soap or non-abrasive household liquid detergent. Dry the surface with a clean cloth or soft paper towel to prevent streaks from appearing.

Care and Maintenance of Metal

Metal surfaces can be wiped with a damp cloth and rubbed dry. A mild non-abrasive household liquid detergent can be used if necessary. Regular maintenance of metal components, including tightening of fasteners and light lubrication of moving parts, will extend the life of your furniture.

Satin Etched Glass

Glass color may vary slightly on multi-piece conference table tops over 180" x 60" when satin etched glass is specified due to the iron content and etching process of the glass.

Care and Maintenance of Glass

Clear or frosted glass may be cleaned with commercial glass cleaner. Be sure to use a lint-free cloth if cleaning the frosted side of the glass.

Stone and Solid Surface Material

Despite its reputation for durability, natural stone can easily be broken during handling and/or installation if proper techniques are not followed. In addition, Nucraft is not responsible for the installation of natural stone or solid surface materials on its products. Therefore, installers specifically trained in the installation of these materials must be utilized to ensure a quality installation. Nucraft shall not be liable for any damages incurred during the handling and/or installation of natural stone or solid surface materials on its products.

Care and Maintenance of Granite

Granite surfaces may be cleaned with a damp cloth and ordinary soap or non-abrasive household liquid detergent. Dry the surface with a clean cloth or soft paper towel to prevent streaks from appearing.

Care and Maintenance of Leather

Genuine leather requires very little care. Nucraft recommends that leather be dusted regularly. If a more thorough cleaning is needed, use lukewarm water and a mild, non-abrasive soap. Generate some lather and lightly rub the surface with cheesecloth. Rinse off any soap film with clean water and towel dry. The leather may dry dull. To restore the leather to a normal gloss, rub it with a clean towel. Never use furniture polish, oil, varnish or ammonia. Saddle soap may be used to prevent the leather from becoming brittle or cracked and to maintain the original supple finish.

Touch Up Finish Kits

Model #	Description	Price
KIT-M	Metal Kit	85
KIT-P	Paint Kit	85
KIT-S	Stain Kit	85

REQUIRED INFORMATION: (ORDER CANNOT BE ENTERED WITHOUT THIS INFORMATION)

- Kit model number
- Quantity of kits
- Specify finish (See pages vi-vii)

General Information:

- Touch-up kits must be ordered on a purchase order separate from Nucraft product due to Hazmat shipping

Retrofit & Replacements

If needing a partial placement or retrofit solution, please reach out to our quote team. Grain/color matched in a set.



ASCARI™ CREDENZA SURFACE MATERIALS

WOOD FINISHES

STANDARD

Default veneer sheen will vary per finish and were determined by a team of experts who reviewed the colorways to determine if gloss or matte best highlighted the natural characteristics of the species of wood and the color of the stain. Default finish is bolded. If no direction is provided, default sheen will be selected.

	Matte	Gloss
Rift Cut Oak		
Carbon	M03	G03

	Matte	Gloss
Flat Cut Oak		
Dune	M05	G05
Portobello	M7413	G7413

	Matte	Gloss
Flaky Oak		
Sahara	M61	G61

	Matte	Gloss
Cherry		
Cognac	M21	G21
Auburn	M93	G93

	Matte	Gloss
Walnut		
Marron	M35	G35
Mocha	M33	G33
Zinc	M30	G30
Onyx	M82	G82
Otter	M31	G31

	Matte	Gloss
Maple		
Natural Maple	M60	G60

	Matte	Gloss
Linea		
Oak Linea	M08	G08
Walnut Linea	M27	G27
Euro Birch Linea	M09	G09
Silver Birch Linea	M10	G10

	Matte	Gloss
Paldao		
Thicket	M75	G75
Paldao	M76	G76
Canyon	M77	G77

PLANK

Plank offers dramatic variations in veneer leaf color, length, and natural characteristics; it stimulates randomly matched veneers

	Matte	Gloss	Coordinating Veneer Case Wood Edge Finish
Plank Walnut			
Clear Coat	M38	G38	

METAL FINISHES

Powder Coat

Aged Bronze	A8010
Black	A44
Burnished	A8009
Cloud	A8004
Foil	A8006
Galaxy	A8007
Moonlight	A87
Satin Bronze	A8011
Shadow	A8005
Storm	A8012

Metal

Clear Anodized*	CA
Polished Chrome*	PC
Polished Stainless*	APS
Satin Bronze Plating*	SBP

*Up-Charge applies.

PAINTS

Aged Bronze	S8010
Black	S44
Burnished	S88
Cloud	S8004
Foil	S8006
Galaxy	S8007
Moonlight	S87
Satin Bronze	S8011
Shadow	S8005
Storm	S8012

Paint to Match

To request a custom paint color, contact Nucraft Customer Service. A paint sample must be matched and approved prior to order.



ASCARI™ CREDENZA SURFACE MATERIALS

STONE TOPS

Stone orders may affect lead times. Please contact NuCraft Customer Service for details.

Stone		Subtop Paint Color
Absolute Black Honed Granite	ST01	S8007
Carrara Marble	ST16	S8004

Quartz | Cambria® Signature

Ainsley	STC100	S8004
Armitage	STC101	S44
Avalene	STC192	S8004
Bellingham	STC102	S8004
Berkeley	STC103	S8004
Berwyn	STC104	S8004
Blackbrook	STC105	S44
Bradshaw	STC106	S8004
Bradwell	STC107	S8004
Cambria Black	STC109	S44
Carrick	STC110	S44
Clifton	STC112	S8004
Colton	STC113	S8004
Copeland	STC200	S8004
Crowndale	STC114	S8004
Devon	STC115	S44
Fairbourne	STC116	S8004
Fieldstone	STC117	S44
Hadley	STC201	S8004
Halewood	STC119	S8004
Hermitage	STC120	S8004
Kendal	STC122	S8004
Laneshaw	STC124	S44
MacBeth	STC202	S8004
Malvern	STC125	S8004
Montgomery	STC128	S8004
New Quay	STC130	S8004
Pendle Hill	STC131	S8004
Praa Sands	STC132	S8004
Ridgegate	STC203	S8004
Rose Bay	STC133	S8004
Sandgate	STC135	S8004
Seacourt	STC204	S8004
Smithfield	STC136	S8004
Sutherland	STC138	S8004
Swanbridge	STC139	S8004
Torquay	STC140	S8004
Trafalgar	STC205	S8004
Travella	STC141	S8004
Weybourne	STC143	S8004
Whitendale	STC206	S8004
Whitney	STC144	S8004
Woodcroft	STC146	S44

Quartz | Cambria® Luxury

Abbey	STC147	S8004
Annaleigh - Luxe	STC193	S8004
Annicca	STC148	S8004
Beckington	STC150	S8004
Bentley	STC151	S8004
Blackpool Matte	STC152	S44
Brighton	STC212	S8004
Brittanicca	STC153	S8004
Brittanicca Gold Cool	STC154	S8004
Brittanicca Gold Warm	STC155	S8004
Brittanicca Warm	STC156	S8004
Clovelly	STC158	S8004
Delamere	STC159	S44
Delgatie	STC160	S8004
Ella	STC161	S8004
Everleigh	STC162	S8004
Everleigh Warm	STC191	S8004
Gladstone	STC163	S8004
Golden Dragon	STC164	S44
Hailey	STC165	S8004
Harlow	STC166	S8004
Hemsworth	STC167	S8004
Huntley	STC168	S8004
Inverness Blakeley	STC190	S8004
Inverness Bristol Bay	STC169	S8004
Inverness Bronze	STC170	S8004
Inverness Cobalt	STC171	S8004
Inverness Everleigh	STC172	S8004
Inverness Frost	STC196	S8004
Inverness Gold	STC197	S8004
Inverness Platinum	STC173	S8004
Inverness Swansea	STC174	S8004
Ironsbridge	STC175	S8004
Iverness Frost	STC176	S8004
Iverness Gold	STC177	S8004
Lakedale	STC179	S8004
Mayfair	STC181	S8004
Mersey	STC182	S44
MonTaj - Luxe & Satin	STC199	S8004
Notting Hill	STC183	S8004
Oakleigh	STC184	S8004
Portrush	STC185	S8004
Queen Anne	STC186	S8006
Remington Brass Satin	STC210	S44
Remington Steel Satin	STC211	S44
Skara Brae	STC187	S8004
Southport	STC188	S8004
White Cliff	STC189	S8004

Quartz | Wilsonart

Carrara Codena	ST21	S8004
Serene	ST17	S8004



ASCARI™ CREDENZA SURFACE MATERIALS

GLASS (SATIN OR GLOSS)

	Satin	Gloss
Black	BS	-
Clove	VS	VG
Meringue	MS	MG
Moonlight	MLS	MLG
Storm	STS	STG
Quill	QS	QG
White	WS	WG

Note: Due to color variation inherent in the natural acid etching process, Satin Etched Glass is not available on tables longer than 180" or wider than 60"

FENIX

	Code	Matching ABS Edgeband
Bianco Kos	0032	962091-017
Grigio Bromo	0724	962091-012
Nero Ingo	0720	962091-003
Grigio Efeso	0725	962091-013

LAMINATES

	Code	Coordinating Veneer Case Wood Edge Finish	Coordinating Woodgrain Edgeband
Wood Grain Laminates			
Formica White Ash	8841-58	M8841	R8841
Formica Natural Ash	8843-58	M8843	R8843
Formica Aged Ash	8844-58	M8844	R8844
Formica Weathered Ash	8842-58	M8842	R8842
Formica Oiled Legno	8846-58	M8846	R8846
Formica Bleached Legno	8845-58	M8845	R8845
Formica Blackened Legno	8848-58	M8848	R8848
Formica Urban Planked Oak	9312-58	M9312	R9312
Formica Thermo Walnut	6402-58	M6402	R6402
Formica Smoky Brown Pear	5488-58	M5488	R5488
Formica Espresso Pear	5489-58	M5489	R5489
Formica Pecan Woodline	5883-58	M5883	R5883
Formica Chestnut Woodline	5884-58	M5884	R5884
Formica Sand Maple	9237-58	G60	W7909
Formica Planked Coffee Oak	7413-58	M7413	F7413

	Code	Matching ABS Edgeband
Solid Laminates		
Formica Brite White	459-58	R01
Formica Dover White	7197-58	R01
Formica Pearl	934-58	R02
Formica Graystone	464-58	R02
Formica Folkstone	927-58	R03
Formica Graphite	837-58	R05

	Code	Matching ABS Edgeband
Patterned Laminates		
Nevamar Cool Chic	VA7002T	R02
Nevamar Serene Stardom	VA5001T	R05
Nevamar Calm Distinction	VA6001T	R05
Nevamar Easy Elegance	VA5002T	R05
Wilsonart Sheer Mesh	4876-38	R02
Wilsonart Grey Mesh	4877-38	R02
Wilsonart Pewter Mesh	4878-38	R05

ABS FINISHES

Ashen	R04
Parchment	R02
Shale	R05
Stone	R03
Whitecap	R01



FABRICS

Knoll Felt* | K1207 | Grade C

Ivory	1
Apple	3
Canary	5
Poppy	7
Cadet	11
Mocha	15
Pewter	17
Tar	20

UltraFabrics Brisa Original | 533 | Grade B

French Vanilla	3866
Birch	3019
White	5747
Bone	3822
Shiitake	3022
New Sand	3946
Bark	3914
Peat	3200
Canyon	3825
Coffee Bean	3023
Black Onyx	5749